

SKG SERVICE LIFTS

ISO-A

2 - 23

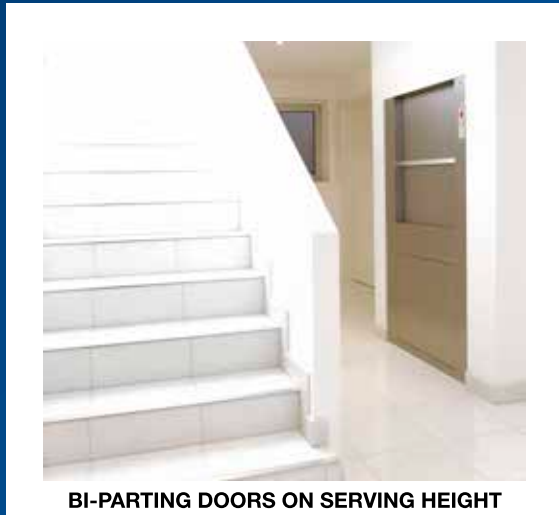

BI-PARTING DOORS ON SERVING HEIGHT

ISO-C

24 - 29

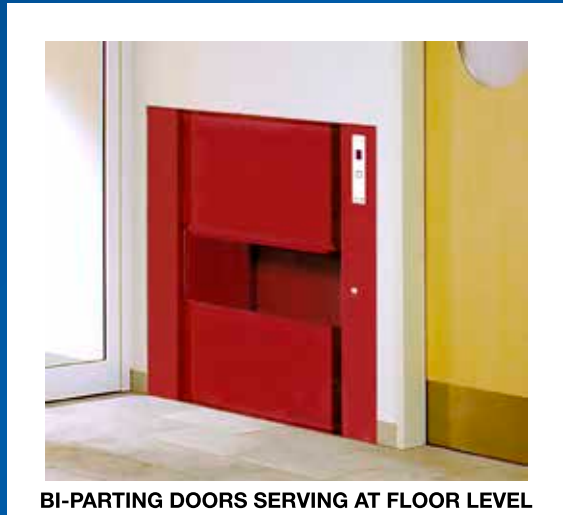

BI-PARTING DOORS SERVING AT FLOOR LEVEL

ISO-D + ISO-U

30 - 53

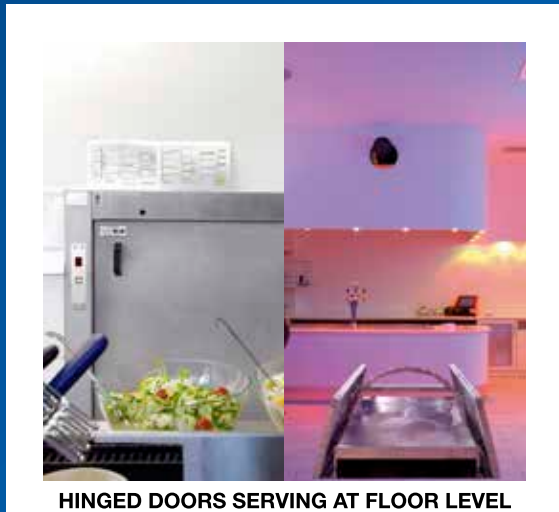

HINGED DOORS SERVING AT FLOOR LEVEL

ISO-Z

54 - 59



CABIN WITH 2 SEPARATE COMPARTMENTS

ISO-L, ISO MAX 300-1000 + FLEX 60 - 73

WITHOUT PASSENGER TRANSPORT

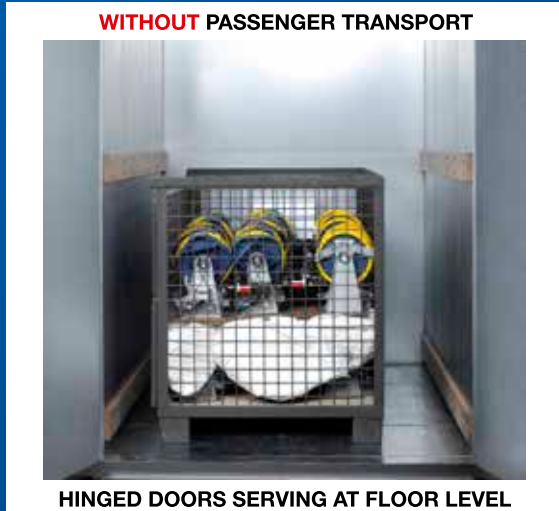

HINGED DOORS SERVING AT FLOOR LEVEL

ISO-PE EASY

74 - 79

WITH 1 TRAINED PERSON

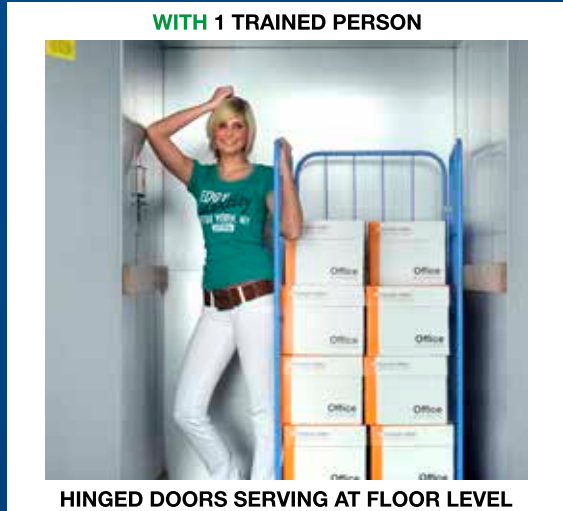

HINGED DOORS SERVING AT FLOOR LEVEL

SERVICE LIFTS

GOODS LIFTS



SERVICE LIFTS
BI-PARTING DOORS ON SERVING HEIGHT ▶▶

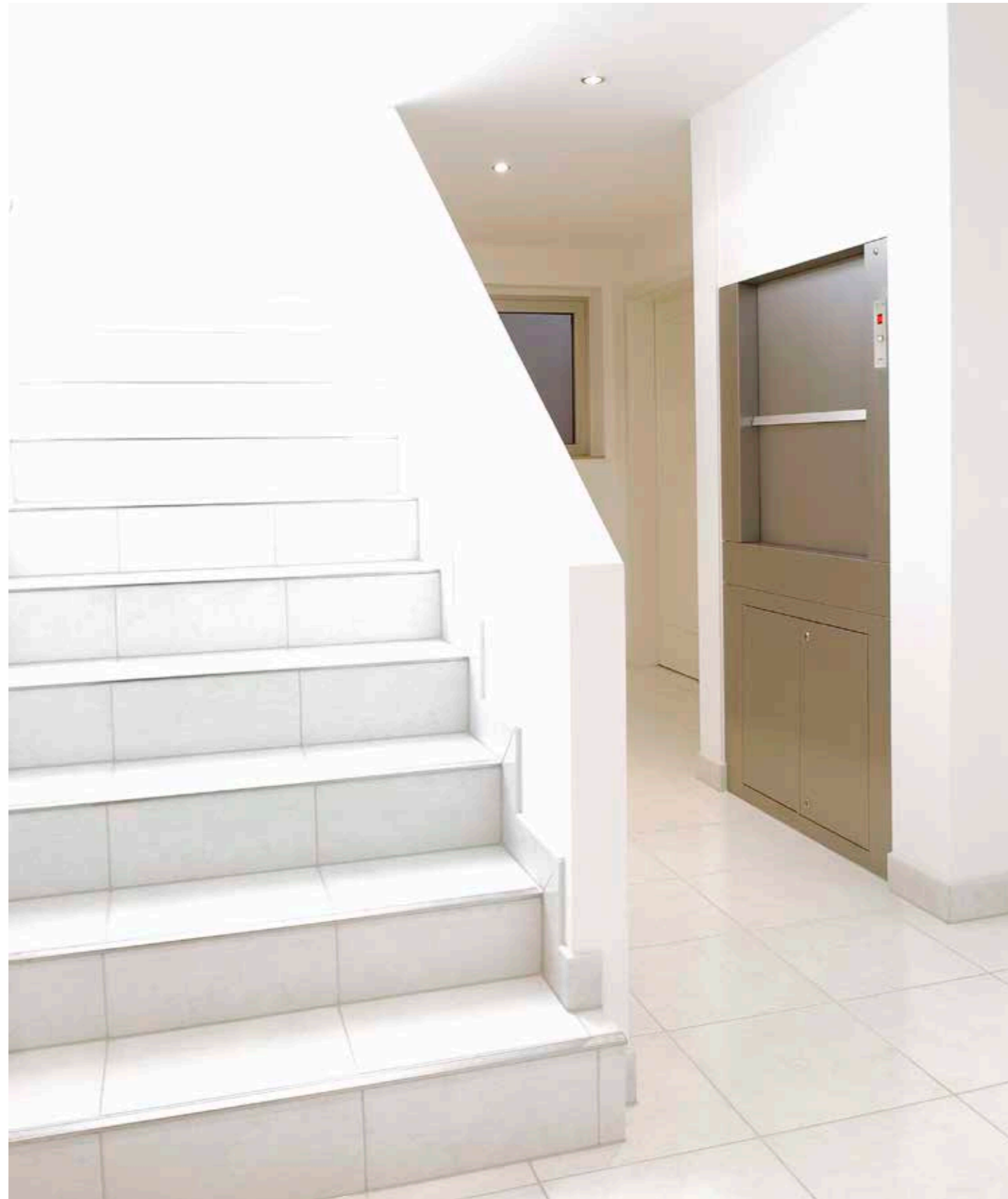

ISO-A

LOADING FRONT AND REAR, MACHINE ABOVE, **WITHOUT SAFETY GEAR**

Shaft dimensions are absolute min. plumbed dimensions. The cabin width, depth and height are available in increments of 25 mm. **ATTENTION:** Cabin protection reduces clear entrance openings resp. shaft sizes (please refer to the SKG-OPTIONS)!

Accessible rooms underneath the shaft are not permitted!

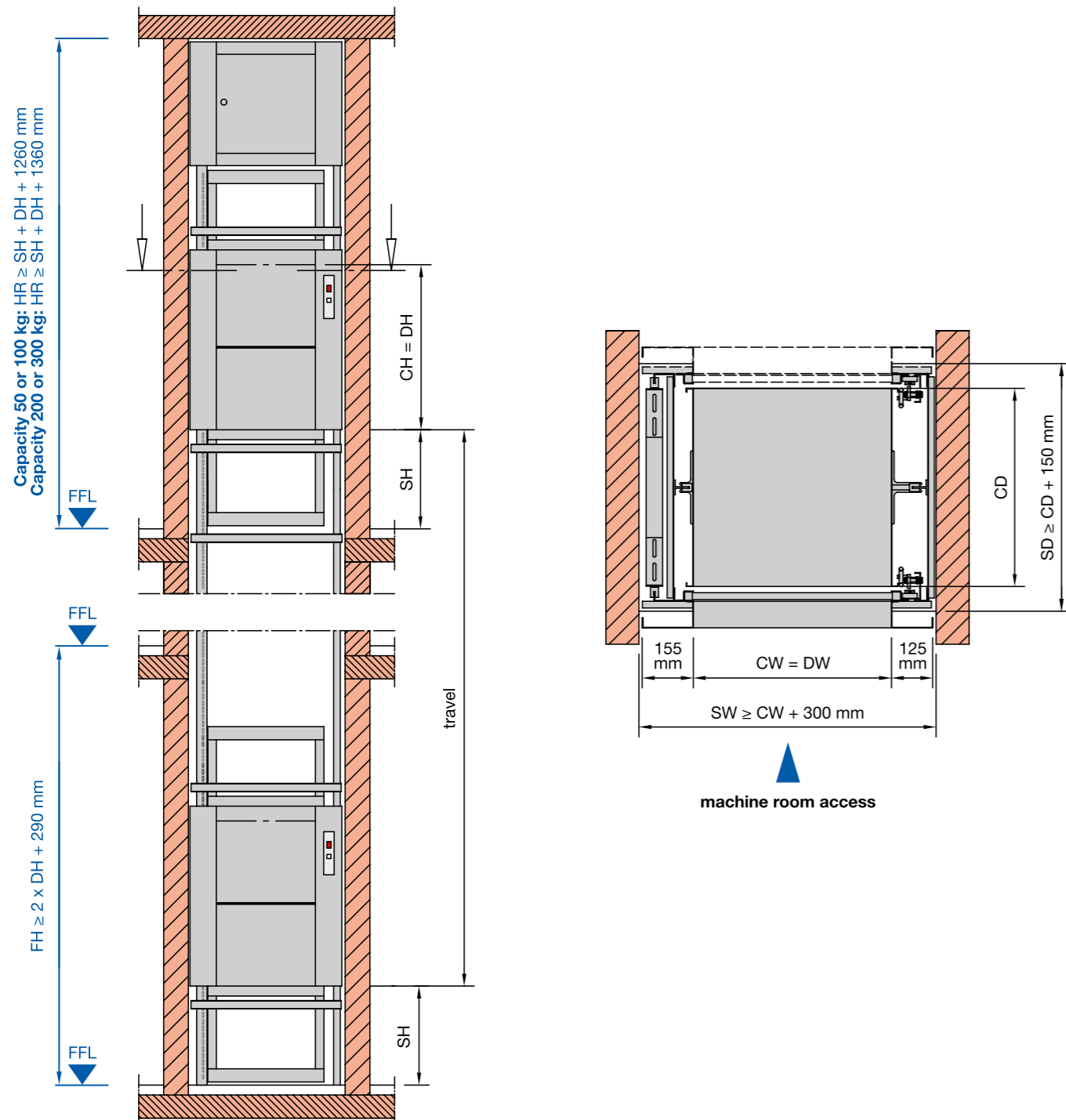

CW	= cabin width	min. 500 to max. 1000 mm	< 500 mm on request
CD	= cabin depth	min. 500 to max. 1000 mm	< 500 mm on request
CH	= cabin height	min. 600 to max. 1200 mm	
DW	= door width	= cabin width	
DH	= door height	= cabin height	
SH	= serving height	= min. 700 mm	
SW	= shaft width	= plumbed min. dimensions	
SD	= shaft depth	= plumbed min. dimensions	
HR	= headroom	= clear height of top floor FFL-underside ceiling	
FFL	= finished floor level		
FH	= floor to floor height on landing doors in line		

LOADING FRONT AND REAR, MACHINE ABOVE, **WITHOUT SAFETY GEAR**

capacity	cabin floor area	speed	2 stops 2 landings	3 stops 3 landings	4 stops 4 landings	5 stops 5 landings	6 stops 6 landings
50 kg	≤ 0,4 m ²	0,4 m/s	3.864,- € A.01.050.04.02	4.899,- € A.01.050.04.03	5.984,- € A.01.050.04.04	7.175,- € A.01.050.04.05	8.548,- € A.01.050.04.06
100 kg	≤ 0,4 m ²	0,4 m/s	3.971,- € A.01.100.04.02	5.007,- € A.01.100.04.03	6.091,- € A.01.100.04.04	7.283,- € A.01.100.04.05	8.655,- € A.01.100.04.06
100 kg	≤ 0,6 m ²	0,4 m/s	4.185,- € A.01.100.06.02	5.221,- € A.01.100.06.03	6.306,- € A.01.100.06.04	7.498,- € A.01.100.06.05	8.869,- € A.01.100.06.06
100 kg	≤ 0,8 m ²	0,4 m/s	4.454,- € A.01.100.08.02	5.490,- € A.01.100.08.03	6.575,- € A.01.100.08.04	7.767,- € A.01.100.08.05	9.138,- € A.01.100.08.06
100 kg	≤ 1,0 m ²	0,4 m/s 0,25 m/s	4.776,- € A.01.100.10.02	5.813,- € A.01.100.10.03	6.896,- € A.01.100.10.04	8.088,- € A.01.100.10.05	9.460,- € A.01.100.10.06
200 kg	≤ 1,0 m ²	0,25 m/s	5.822,- € A.01.200.10.02	6.859,- € A.01.200.10.03	7.943,- € A.01.200.10.04	9.135,- € A.01.200.10.05	10.507,- € A.01.200.10.06
300 kg	≤ 1,0 m ²	0,25 m/s	5.849,- € A.01.300.10.02	6.886,- € A.01.300.10.03	7.970,- € A.01.300.10.04	9.162,- € A.01.300.10.05	10.533,- € A.01.300.10.06

from 7 stops and 7 landings prices on request

- ▶ standard complies to EN 81-3 + EU-MRL2006/42/EC
- ▶ 3 meters of travel included for each stop

ATTENTION:

According to EN-81-3 part 8.5 Car entrance, a load protection can be necessary. See extra prices in SKG-OPTIONS on pages 10 and 11.

STANDARD EQUIPMENT AT NO EXTRA-CHARGE

STRUCTURE

- ▶ steel structure, made of cold rolled galvanized special profiles
- ▶ pre-installed with T-guides T 45 x 5 mm and plastic trunking in 2-meter-segments

CABIN

- ▶ „cant-off“-system made of galvanized steel, adjustable guide shoes on both sides
- ▶ removable shelf
- ▶ compensation device on suspension ropes / chains

BI-PARTING DOORS

- ▶ manual operated bi-parting doors made of galvanized steel in accordance to DIN 18092, production controlled by TÜV-authorities
- ▶ side frames made of galvanized steel according to drawing
- ▶ door locks type-tested by TÜV-authorities

MACHINE ROOM DOOR

- ▶ single hinged door (DW ≥ 800 mm = double hinged), with sash lock, both hinging sides available
- ▶ side frames made of galvanized steel according to drawing

DRIVE UNIT

- ▶ drive unit with factory oil filling, standard motor IP54, disc brake and hand wheel, 3 x 400 V / 50 Hz. according to IEC
- ▶ capacity = 50 or 100 kg: sheave Ø 300 diameter for 2 resp. 3 ropes Ø 6 mm
- ▶ capacity = 200 or 300 kg: 2 chain wheels for 2 chains 5/8 x 3/8" DIN 8187

COUNTERWEIGHT OR BALANCE WEIGHT

- ▶ galvanized frame construction with iron infills

CONTROLLER

- ▶ call and send control with 24 V, safety circuit 48 V
- ▶ pre-wired with plugs
- ▶ acoustic arrival signal
- ▶ position indicator on each entrance
- ▶ machine room light with socket

LOADING FRONT AND REAR, MACHINE ABOVE, WITH SAFETY GEAR

Shaft dimensions are absolute min. plumbed dimensions. The cabin width, depth and height are available in increments of 25 mm. **ATTENTION:** Cabin protection reduces clear entrance openings resp. shaft sizes (please refer to the SKG-OPTIONS)!

The shaft bottom must be carried out according to the construction drawing!

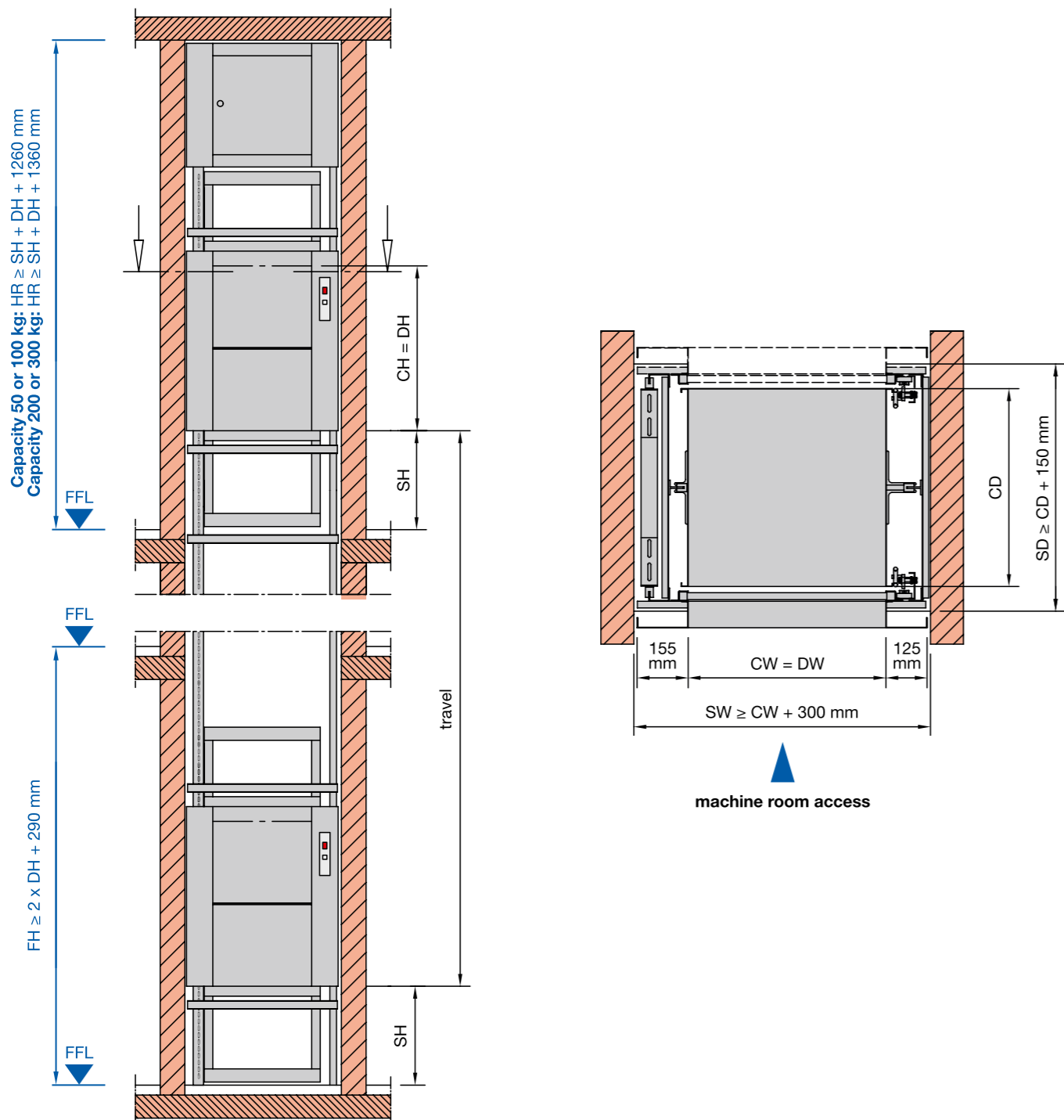

- CW = cabin width = min. 600 to max. 1000 mm < 600 mm on request
- CD = cabin depth = min. 700 to max. 1000 mm < 700 mm on request
- CH = cabin height = min. 600 to max. 1200 mm
- DW = door width = cabin width
- DH = door height = cabin height
- SH = serving height = lowest min. 800 mm, others min. 700 mm
- SW = shaft width = plumbed min. dimensions
- SD = shaft depth = plumbed min. dimensions
- HR = headroom = clear height of top floor FFL-underside ceiling
- FFL = finished floor level
- FH = floor to floor height on landing doors in line

LOADING FRONT AND REAR, MACHINE ABOVE, WITH SAFETY GEAR

capacity	cabin floor area	speed	2 stops 2 landings	3 stops 3 landings	4 stops 4 landings	5 stops 5 landings	6 stops 6 landings
50 kg	≤ 0,4 m ²	0,3 m/s	6.513,- € A.02.050.04.02	7.550,- € A.02.050.04.03	8.634,- € A.02.050.04.04	9.826,- € A.02.050.04.05	11.197,- € A.02.050.04.06
100 kg	≤ 0,4 m ²	0,3 m/s	6.620,- € A.02.100.04.02	7.657,- € A.02.100.04.03	8.741,- € A.02.100.04.04	9.933,- € A.02.100.04.05	11.304,- € A.02.100.04.06
100 kg	≤ 0,6 m ²	0,3 m/s	6.836,- € A.02.100.06.02	7.872,- € A.02.100.06.03	8.957,- € A.02.100.06.04	10.148,- € A.02.100.06.05	11.520,- € A.02.100.06.06
100 kg	≤ 0,8 m ²	0,3 m/s	7.104,- € A.02.100.08.02	8.140,- € A.02.100.08.03	9.224,- € A.02.100.08.04	10.416,- € A.02.100.08.05	11.788,- € A.02.100.08.06
100 kg	≤ 1,0 m ²	0,3 m/s	7.667,- € A.02.100.10.02	8.462,- € A.02.100.10.03	9.547,- € A.02.100.10.04	10.738,- € A.02.100.10.05	12.110,- € A.02.100.10.06
200 kg	≤ 1,0 m ²	0,15 m/s	8.472,- € A.02.200.10.02	9.509,- € A.02.200.10.03	10.593,- € A.02.200.10.04	11.785,- € A.02.200.10.05	13.157,- € A.02.200.10.06
300 kg	≤ 1,0 m ²	0,15 m/s	8.660,- € A.02.300.10.02	9.697,- € A.02.300.10.03	10.781,- € A.02.300.10.04	11.973,- € A.02.300.10.05	13.344,- € A.02.300.10.06

from 7 stops and 7 landings prices on request

- ▶ standard complies to EN 81-3 + EU-MRL2006/42/EC
- ▶ 3 meters of travel included for each stop

ATTENTION:

According to EN-81-3 part 8.5 Car entrance, a load protection can be necessary. See extra prices in SKG-OPTIONS on pages 10 and 11.

STANDARD EQUIPMENT AT NO EXTRA-CHARGE

STRUCTURE

- ▶ steel structure, made of cold rolled galvanized special profiles
- ▶ pre-installed with T-guides T 45 x 5 mm and plastic trunking in 2-meter-segments
- ▶ buffer Ø 80 mm

CABIN

- ▶ „cant-off“-system made of galvanized steel, adjustable guide shoes on both sides
- ▶ removable shelf
- ▶ compensation device on suspension ropes / chains
- ▶ safety gear, type tested by TÜV-authorities

BI-PARTING DOORS

- ▶ manual operated bi-parting doors made of galvanized steel in accordance to DIN 18092, production controlled by TÜV-authorities
- ▶ side frames made of galvanized steel according to drawing
- ▶ door locks type-tested by TÜV-authorities

MACHINE ROOM DOOR

- ▶ single hinged door (DW ≥ 800 mm = double hinged), with sash lock, both hinging sides available
- ▶ side frames made of galvanized steel according to drawing

DRIVE UNIT

- ▶ drive unit with factory oil filling, standard motor IP54, disc brake and hand wheel, 3 x 400 V / 50 Hz. according to IEC
- ▶ drum 240 diameter for 2 ropes 5 or 6 mm diameter

CONTROLLER

- ▶ call and send control with 24 V, safety circuit 48 V
- ▶ pre-wired with plugs
- ▶ acoustic arrival signal
- ▶ position indicator on each entrance
- ▶ machine room light with socket

Note: If travel is more than 4 meters, please contact us if drum will fit in the shaft!

LOADING FRONT AND REAR, MACHINE SIDE ABOVE, **WITHOUT SAFETY GEAR**

Shaft dimensions are absolute min. plumbed dimensions. The cabin width, depth and height are available in increments of 25 mm. **ATTENTION:** Cabin protection reduces clear entrance openings resp. shaft sizes (please refer to the SKG-OPTIONS)!

Accessible rooms underneath the shaft are not permitted!

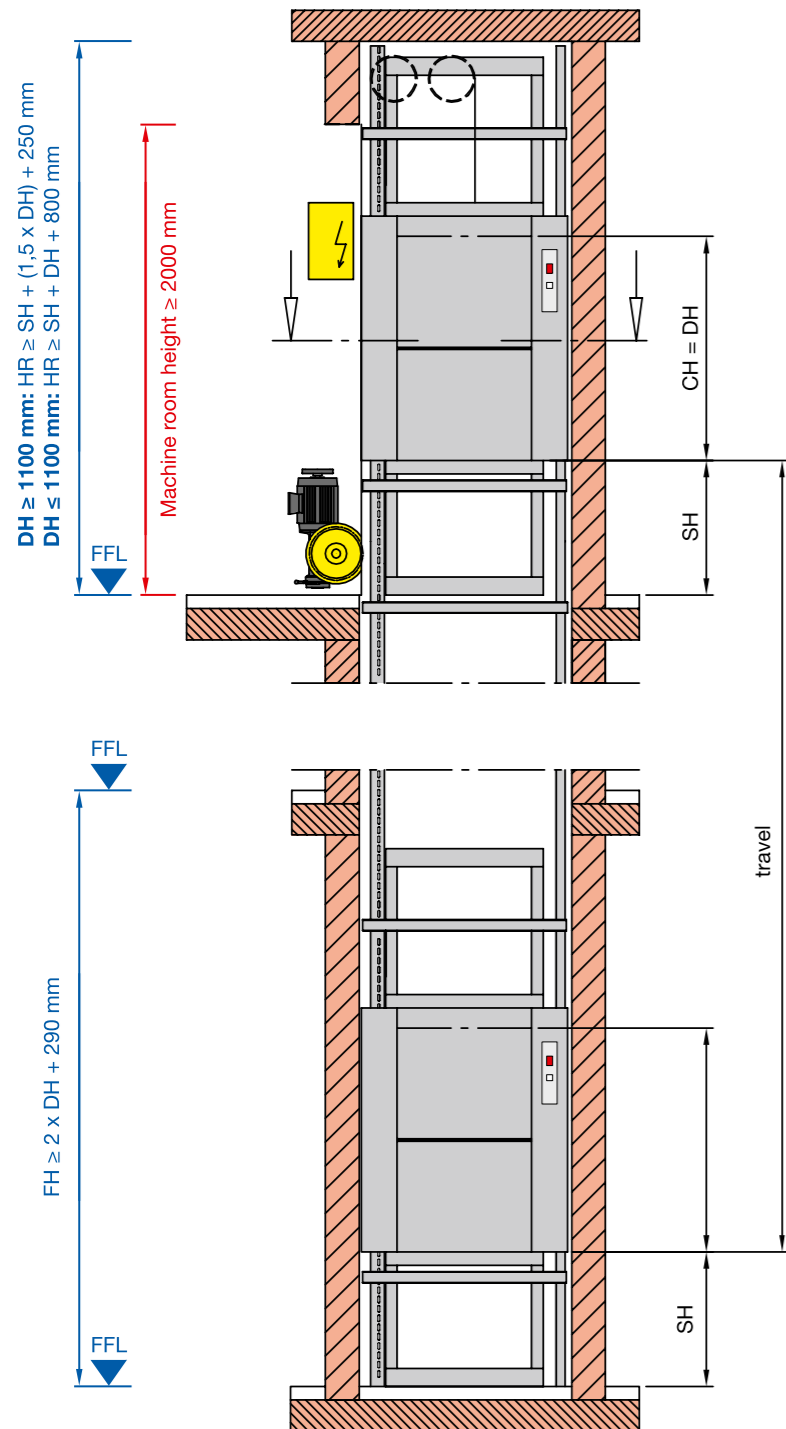

ATTENTION: Machine room door by others!

Please indicate the position of the machine room (left or right) to be advised in relation to the upper landing door!

Machine room width = shaft depth

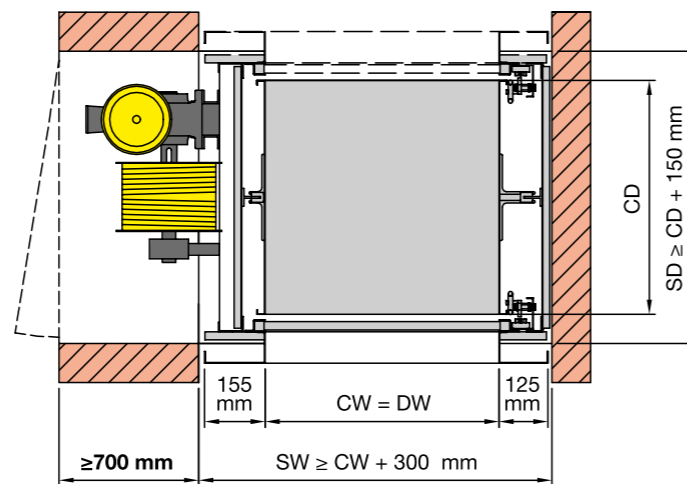

- CW = cabin width = min. 500 to max. 1000 mm
- CD = cabin depth = min. 650 to max. 1000 mm
- CH = cabin height = min. 600 to max. 1200 mm
- DW = door width = cabin width
- DH = door height = cabin height
- SH = serving height = min. 700 mm
- SW = shaft width = plumbed min. dimensions
- SD = shaft depth = plumbed min. dimensions
- HR = headroom = clear height of top floor FFL-underside ceiling
- FFL = finished floor level
- FH = floor to floor height on landing doors in line

LOADING FRONT AND REAR, MACHINE SIDE ABOVE, **WITHOUT SAFETY GEAR**

capacity	cabin floor area	speed	2 stops 2 landings	3 stops 3 landings	4 stops 4 landings	5 stops 5 landings	6 stops 6 landings
50 kg	≤ 0,4 m ²	0,3 m/s	5.420,- € A.03.050.04.02	6.456,- € A.03.050.04.03	7.541,- € A.03.050.04.04	8.733,- € A.03.050.04.05	10.104,- € A.03.050.04.06
100 kg	≤ 0,4 m ²	0,3 m/s	5.528,- € A.03.100.04.02	6.563,- € A.03.100.04.03	7.648,- € A.03.100.04.04	8.840,- € A.03.100.04.05	10.212,- € A.03.100.04.06
100 kg	≤ 0,6 m ²	0,3 m/s	5.742,- € A.03.100.06.02	6.779,- € A.03.100.06.03	7.863,- € A.03.100.06.04	9.054,- € A.03.100.06.05	10.426,- € A.03.100.06.06
100 kg	≤ 0,8 m ²	0,3 m/s	6.011,- € A.03.100.08.02	7.046,- € A.03.100.08.03	8.131,- € A.03.100.08.04	9.323,- € A.03.100.08.05	10.695,- € A.03.100.08.06
100 kg	≤ 1,0 m ²	0,3 m/s	6.332,- € A.03.100.10.02	7.369,- € A.03.100.10.03	8.453,- € A.03.100.10.04	9.645,- € A.03.100.10.05	11.016,- € A.03.100.10.06
200 kg	≤ 1,0 m ²	0,15 m/s	7.379,- € A.03.200.10.02	8.416,- € A.03.200.10.03	9.500,- € A.03.200.10.04	10.692,- € A.03.200.10.05	12.064,- € A.03.200.10.06
300 kg	≤ 1,0 m ²	0,15 m/s	7.541,- € A.03.300.10.02	8.577,- € A.03.300.10.03	9.661,- € A.03.300.10.04	10.854,- € A.03.300.10.05	12.225,- € A.03.300.10.06

from 7 stops and 7 landings prices on request

- ▶ standard complies to EN 81-3 + EU-MRL2006/42/EC
- ▶ 3 meters of travel included for each stop

ATTENTION:

According to EN-81-3 part 8.5 Car entrance, a load protection can be necessary. See extra prices in SKG-OPTIONS on pages 10 and 11.

STANDARD EQUIPMENT AT NO EXTRA-CHARGE

STRUCTURE

- ▶ steel structure, made of cold rolled galvanized special profiles
- ▶ pre-installed with T-guides T 45 x 5 mm and plastic trunking in 2-meter-segments

CABIN

- ▶ „cant-off“-system made of galvanized steel, adjustable guide shoes on both sides
- ▶ removable shelf
- ▶ compensation device on suspension ropes / chains

BI-PARTING DOORS

- ▶ manual operated bi-parting doors made of galvanized steel in accordance to DIN 18092, production controlled by TÜV-authorities
- ▶ side frames made of galvanized steel according to drawing
- ▶ door locks type-tested by TÜV-authorities

DRIVE UNIT

- ▶ drive unit with factory oil filling, standard motor IP54, disc brake and hand wheel, 3 x 400 V / 50 Hz. according to IEC
- ▶ drum 240 diameter for 2 ropes 5 or 6 mm diameter

CONTROLLER

- ▶ call and send control with 24 V, safety circuit 48 V
- ▶ pre-wired with plugs
- ▶ acoustic arrival signal
- ▶ position indicator on each entrance
- ▶ machine room light with socket

Note: If travel is more than 4 meters, please contact us if drum will fit in the shaft!

LOADING FRONT AND REAR, MACHINE SIDE ABOVE, WITH SAFETY GEAR

Shaft dimensions are absolute min. plumbed dimensions. The cabin width, depth and height are available in increments of 25 mm. **ATTENTION:** Cabin protection reduces clear entrance openings resp. shaft sizes (please refer to the SKG-OPTIONS)!

The shaft bottom must be carried out according to the construction drawing!

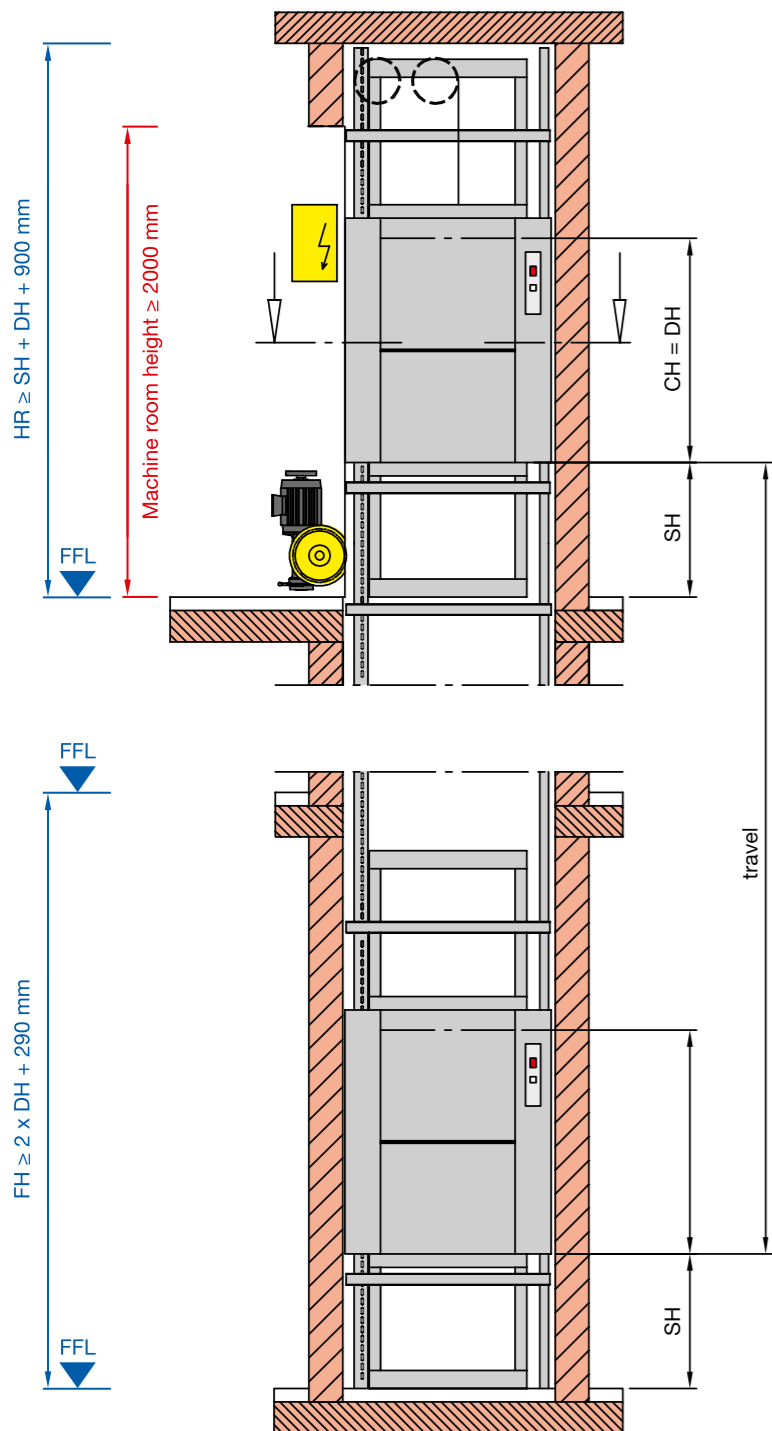

ATTENTION: Machine room door by others!

Please indicate the position of the machine room (left or right) to be advised in relation to the lower landing door!

Machine room width = shaft depth

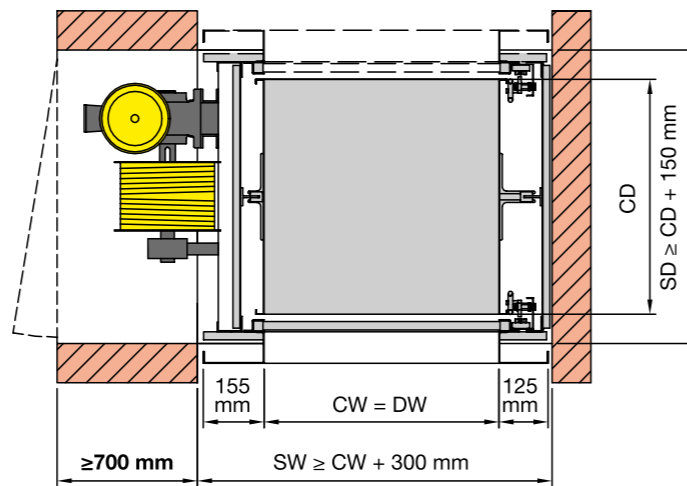

- CW = cabin width = min. 500 to max. 1000 mm
- CD = cabin depth = min. 700 to max. 1000 mm
- CH = cabin height = min. 600 to max. 1200 mm
- DW = door width = cabin width
- DH = door height = cabin height
- SH = serving height = lowest min. 800 mm, others min. 700 mm
- SW = shaft width = plumbed min. dimensions
- SD = shaft depth = plumbed min. dimensions
- HR = headroom = clear height of top floor FFL-underside ceiling
- FFL = finished floor level
- FH = floor to floor height on landing doors in line

LOADING FRONT AND REAR, MACHINE SIDE ABOVE, WITH SAFETY GEAR

capacity	cabin floor area	speed	2 stops 2 landings	3 stops 3 landings	4 stops 4 landings	5 stops 5 landings	6 stops 6 landings
50 kg	≤ 0,4 m ²	0,3 m/s	7.050,- € A.04.050.04.02	8.086,- € A.04.050.04.03	9.171,- € A.04.050.04.04	10.362,- € A.04.050.04.05	11.734,- € A.04.050.04.06
100 kg	≤ 0,4 m ²	0,3 m/s	7.158,- € A.04.100.04.02	8.194,- € A.04.100.04.03	9.278,- € A.04.100.04.04	10.470,- € A.04.100.04.05	11.842,- € A.04.100.04.06
100 kg	≤ 0,6 m ²	0,3 m/s	7.372,- € A.04.100.06.02	8.408,- € A.04.100.06.03	9.493,- € A.04.100.06.04	10.685,- € A.04.100.06.05	12.056,- € A.04.100.06.06
100 kg	≤ 0,8 m ²	0,3 m/s	7.641,- € A.04.100.08.02	8.677,- € A.04.100.08.03	9.761,- € A.04.100.08.04	10.954,- € A.04.100.08.05	12.325,- € A.04.100.08.06
100 kg	≤ 1,0 m ²	0,3 m/s	7.963,- € A.04.100.10.02	8.999,- € A.04.100.10.03	10.083,- € A.04.100.10.04	11.275,- € A.04.100.10.05	12.647,- € A.04.100.10.06
200 kg	≤ 1,0 m ²	0,15 m/s	9.010,- € A.04.200.10.02	10.045,- € A.04.200.10.03	11.130,- € A.04.200.10.04	12.322,- € A.04.200.10.05	13.694,- € A.04.200.10.06
300 kg	≤ 1,0 m ²	0,15 m/s	9.198,- € A.04.300.10.02	10.233,- € A.04.300.10.03	11.318,- € A.04.300.10.04	12.510,- € A.04.300.10.05	13.882,- € A.04.300.10.06

from 7 stops and 7 landings prices on request

- ▶ standard complies to EN 81-3 + EU-MRL2006/42/EC
- ▶ 3 meters of travel included for each stop

ATTENTION:

According to EN-81-3 part 8.5 Car entrance, a load protection can be necessary. See extra prices in SKG-OPTIONS on pages 10 and 11.

STANDARD EQUIPMENT AT NO EXTRA-CHARGE

STRUCTURE

- ▶ steel structure, made of cold rolled galvanized special profiles
- ▶ pre-installed with T-guides T 45 x 5 mm and plastic trunking in 2-meter-segments
- ▶ buffer Ø 80 mm

CABIN

- ▶ „cant-off“-system made of galvanized steel, adjustable guide shoes on both sides
- ▶ removable shelf
- ▶ compensation device on suspension ropes / chains
- ▶ safety gear, type tested by TÜV-authorities

BI-PARTING DOORS

- ▶ manual operated bi-parting doors made of galvanized steel in accordance to DIN 18092, production controlled by TÜV-authorities
- ▶ side frames made of galvanized steel according to drawing
- ▶ door locks type-tested by TÜV-authorities

DRIVE UNIT

- ▶ drive unit with factory oil filling, standard motor IP54, disc brake and hand wheel, 3 x 400 V / 50 Hz. according to IEC
- ▶ drum 240 diameter for 2 ropes 5 or 6 mm diameter

CONTROLLER

- ▶ call and send control with 24 V, safety circuit 48 V
- ▶ pre-wired with plugs
- ▶ acoustic arrival signal
- ▶ position indicator on each entrance
- ▶ machine room light with socket

Note: If travel is more than 4 meters, please contact us if drum will fit in the shaft!

LOADING FRONT AND REAR, MACHINE SIDE BELOW, **WITHOUT SAFETY GEAR**

Shaft dimensions are absolute min. plumbed dimensions. The cabin width, depth and height are available in increments of 25 mm. **ATTENTION:** Cabin protection reduces clear entrance openings resp. shaft sizes (please refer to the SKG-OPTIONS)!

Accessible rooms underneath the shaft are not permitted!

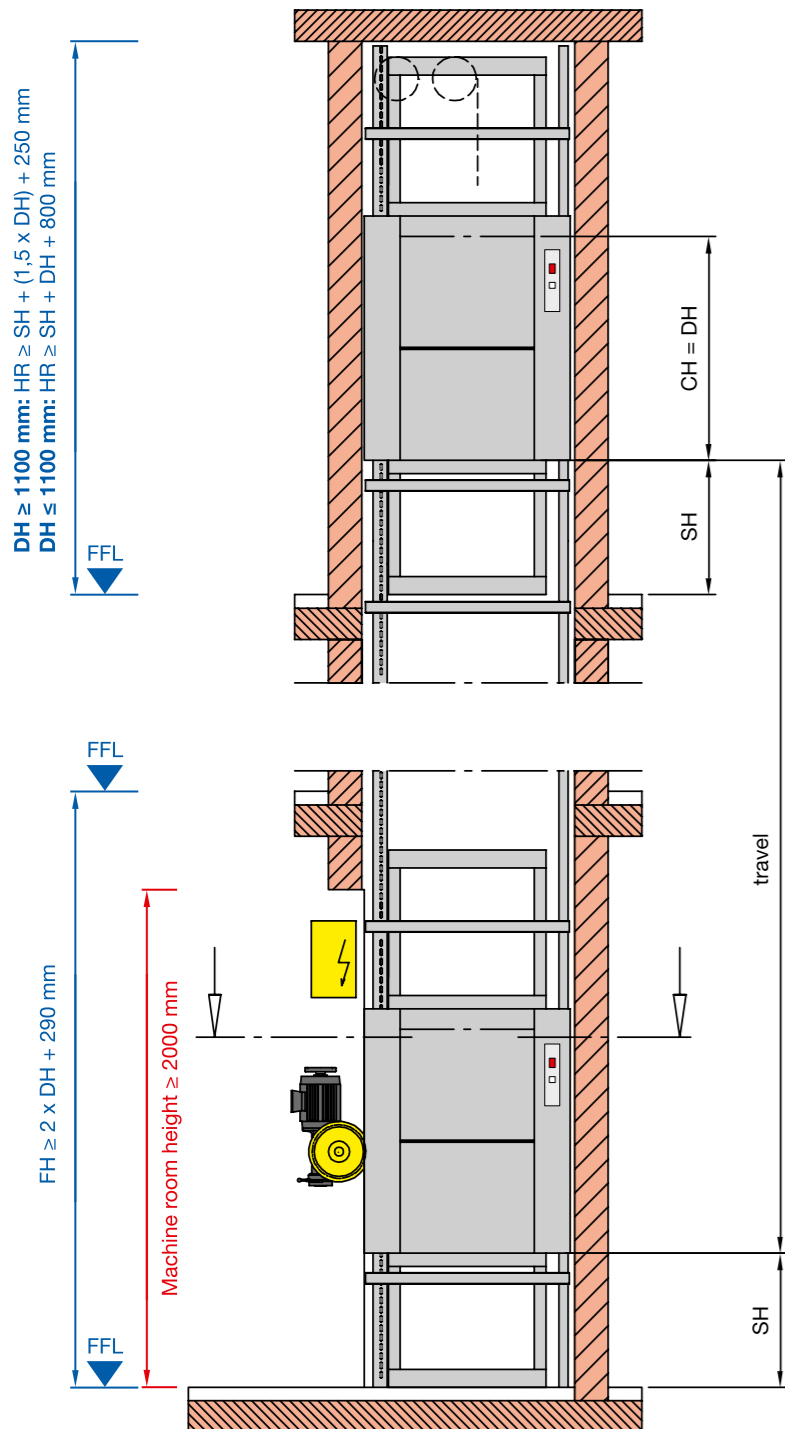

ATTENTION: Machine room door by others!
Please indicate the position of the machine room (left or right) to be advised in relation to the lower landing door!

Machine room width = shaft depth

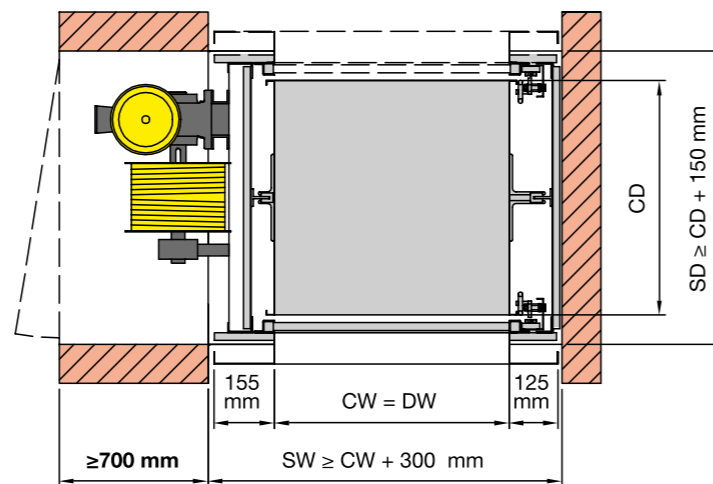

- CW = cabin width = min. 500 to max. 1000 mm
- CD = cabin depth = min. 650 to max. 1000 mm
- CH = cabin height = min. 600 to max. 1200 mm
- DW = door width = cabin width
- DH = door height = cabin height
- SH = serving height = min. 700 mm
- SW = shaft width = plumbed min. dimensions
- SD = shaft depth = plumbed min. dimensions
- HR = headroom = clear height of top floor FFL-underside ceiling
- FFL = finished floor level
- FH = floor to floor height on landing doors in line

LOADING FRONT AND REAR, MACHINE SIDE BELOW, **WITHOUT SAFETY GEAR**

capacity	cabin floor area	speed	2 stops 2 landings	3 stops 3 landings	4 stops 4 landings	5 stops 5 landings	6 stops 6 landings
50 kg	≤ 0,4 m ²	0,3 m/s	5.420,- € A.05.050.04.02	6.456,- € A.05.050.04.03	7.541,- € A.05.050.04.04	8.733,- € A.05.050.04.05	10.104,- € A.05.050.04.06
100 kg	≤ 0,4 m ²	0,3 m/s	5.528,- € A.05.100.04.02	6.563,- € A.05.100.04.03	7.648,- € A.05.100.04.04	8.840,- € A.05.100.04.05	10.212,- € A.05.100.04.06
100 kg	≤ 0,6 m ²	0,3 m/s	5.742,- € A.05.100.06.02	6.779,- € A.05.100.06.03	7.863,- € A.05.100.06.04	9.054,- € A.05.100.06.05	10.426,- € A.05.100.06.06
100 kg	≤ 0,8 m ²	0,3 m/s	6.011,- € A.05.100.08.02	7.046,- € A.05.100.08.03	8.131,- € A.05.100.08.04	9.323,- € A.05.100.08.05	10.695,- € A.05.100.08.06
100 kg	≤ 1,0 m ²	0,3 m/s	6.332,- € A.05.100.10.02	7.369,- € A.05.100.10.03	8.453,- € A.05.100.10.04	9.645,- € A.05.100.10.05	11.016,- € A.05.100.10.06
200 kg	≤ 1,0 m ²	0,15 m/s	7.379,- € A.05.200.10.02	8.416,- € A.05.200.10.03	9.500,- € A.05.200.10.04	10.692,- € A.05.200.10.05	12.064,- € A.05.200.10.06
300 kg	≤ 1,0 m ²	0,15 m/s	7.541,- € A.05.300.10.02	8.577,- € A.05.300.10.03	9.661,- € A.05.300.10.04	10.854,- € A.05.300.10.05	12.225,- € A.05.300.10.06

from 7 stops and 7 landings prices on request

- ▶ standard complies to EN 81-3 + EU-MRL2006/42/EC
- ▶ 3 meters of travel included for each stop

ATTENTION:

According to EN-81-3 part 8.5 Car entrance, a load protection can be necessary. See extra prices in SKG-OPTIONS on pages 10 and 11.

STANDARD EQUIPMENT AT NO EXTRA-CHARGE

STRUCTURE

- ▶ steel structure, made of cold rolled galvanized special profiles
- ▶ pre-installed with T-guides T 45 x 5 mm and plastic trunking in 2-meter-segments

CABIN

- ▶ „cant-off“-system made of galvanized steel, adjustable guide shoes on both sides
- ▶ removable shelf
- ▶ compensation device on suspension rops

BI-PARTING DOORS

- ▶ manual operated bi-parting doors made of galvanized steel in accordance to DIN 18092, production controlled by TÜV-authorities
- ▶ side frames made of galvanized steel according to drawing
- ▶ door locks type-tested by TÜV-authorities

DRIVE UNIT

- ▶ drive unit with factory oil filling, standard motor IP54, disc brake and hand wheel, 3 x 400 V / 50 Hz. according to IEC
- ▶ drum 240 diameter for 2 ropes 5 or 6 mm diameter

CONTROLLER

- ▶ call and send control with 24 V, safety circuit 48 V
- ▶ pre-wired with plugs
- ▶ acoustic arrival signal
- ▶ position indicator on each entrance
- ▶ machine room light with socket

Note: If travel is more than 4 meters, please contact us if drum will fit in the shaft!

LOADING FRONT AND REAR, MACHINE SIDE BELOW, WITH SAFETY GEAR

Shaft dimensions are absolute min. plumbed dimensions. The cabin width, depth and height are available in increments of 25 mm. **ATTENTION:** Cabin protection reduces clear entrance openings resp. shaft sizes (please refer to the SKG-OPTIONS)!

The shaft bottom must be carried out according to the construction drawing!

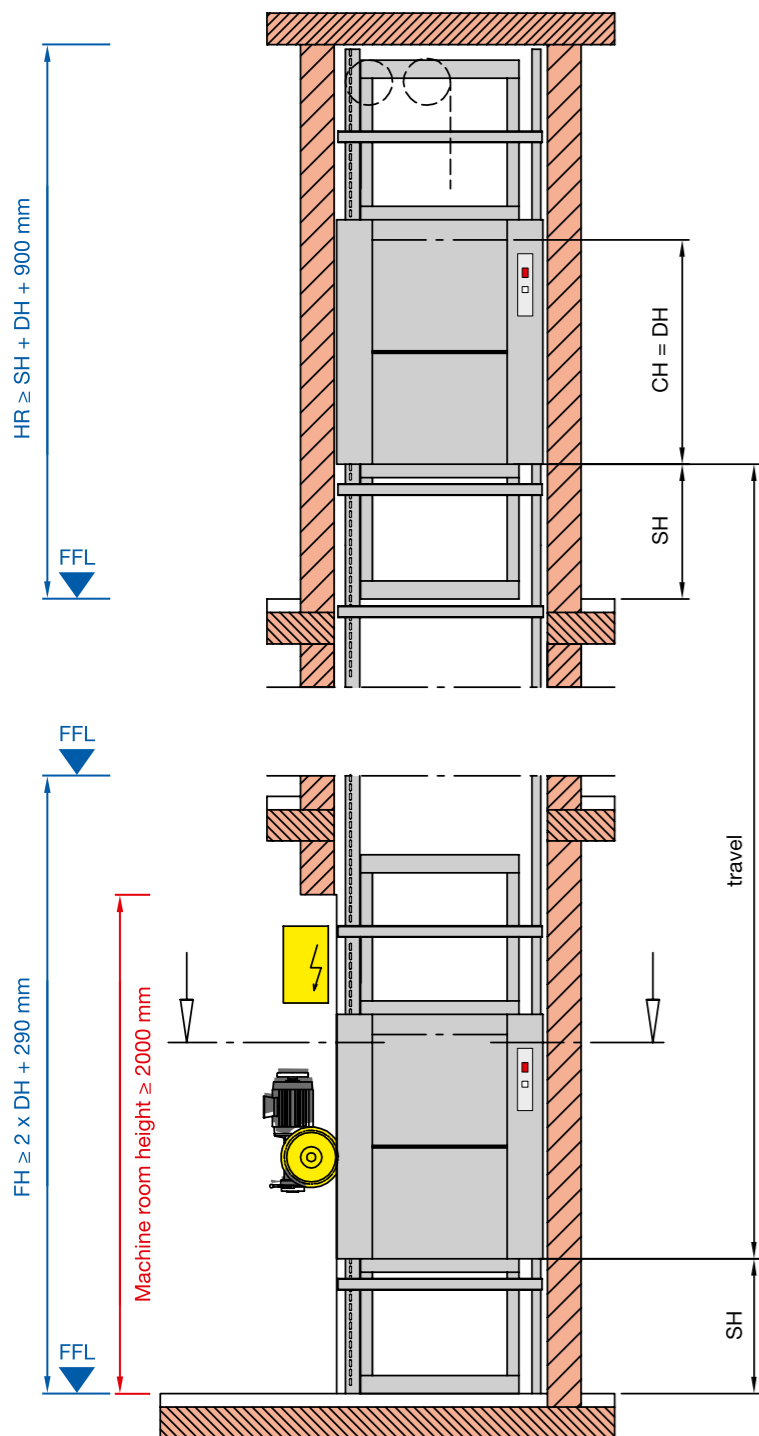

ATTENTION: Machine room door by others!
Please indicate the position of the machine room (left or right) to be advised in relation to the lower landing door!

Machine room width = shaft depth

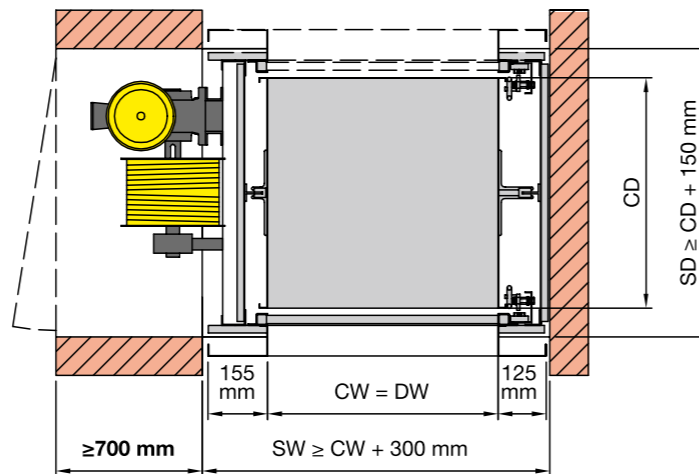

- CW = cabin width = min. 500 to max. 1000 mm
- CD = cabin depth = min. 700 to max. 1000 mm
- CH = cabin height = min. 600 to max. 1200 mm
- DW = door width = cabin width
- DH = door height = cabin height
- SH = serving height = lowest min. 800 mm, others min. 700 mm
- SW = shaft width = plumbed min. dimensions
- SD = shaft depth = plumbed min. dimensions
- HR = headroom = clear height of top floor FFL-underside ceiling
- FFL = finished floor level
- FH = floor to floor height on landing doors in line

LOADING FRONT AND REAR, MACHINE SIDE BELOW, WITH SAFETY GEAR

capacity	cabin floor area	speed	2 stops 2 landings	3 stops 3 landings	4 stops 4 landings	5 stops 5 landings	6 stops 6 landings
50 kg	≤ 0,4 m ²	0,3 m/s	7.050,- € A.06.050.04.02	8.086,- € A.06.050.04.03	9.171,- € A.06.050.04.04	10.362,- € A.06.050.04.05	11.734,- € A.06.050.04.06
100 kg	≤ 0,4 m ²	0,3 m/s	7.158,- € A.06.100.04.02	8.194,- € A.06.100.04.03	9.278,- € A.06.100.04.04	10.470,- € A.06.100.04.05	11.842,- € A.06.100.04.06
100 kg	≤ 0,6 m ²	0,3 m/s	7.372,- € A.06.100.06.02	8.408,- € A.06.100.06.03	9.493,- € A.06.100.06.04	10.685,- € A.06.100.06.05	12.056,- € A.06.100.06.06
100 kg	≤ 0,8 m ²	0,3 m/s	7.641,- € A.06.100.08.02	8.677,- € A.06.100.08.03	9.761,- € A.06.100.08.04	10.954,- € A.06.100.08.05	12.325,- € A.06.100.08.06
100 kg	≤ 1,0 m ²	0,3 m/s	7.963,- € A.06.100.10.02	8.999,- € A.06.100.10.03	10.083,- € A.06.100.10.04	11.275,- € A.06.100.10.05	12.647,- € A.06.100.10.06
200 kg	≤ 1,0 m ²	0,15 m/s	9.010,- € A.06.200.10.02	10.045,- € A.06.200.10.03	11.130,- € A.06.200.10.04	12.322,- € A.06.200.10.05	13.694,- € A.06.200.10.06
300 kg	≤ 1,0 m ²	0,15 m/s	9.198,- € A.06.300.10.02	10.233,- € A.06.300.10.03	11.318,- € A.06.300.10.04	12.510,- € A.06.300.10.05	13.882,- € A.06.300.10.06

from 7 stops and 7 landings prices on request

- ▶ standard complies to EN 81-3 + EU-MRL2006/42/EC
- ▶ 3 meters of travel for each stop

ATTENTION:
According to EN-81-3 part 8.5 Car entrance, a load protection can be necessary. See extra prices in SKG-OPTIONS on pages 10 and 11.

STANDARD EQUIPMENT AT NO EXTRA-CHARGE

STRUCTURE

- ▶ steel structure, made of cold rolled galvanized special profiles
- ▶ pre-installed with T-guides T 45 x 5 mm and plastic trunking in 2-meter-segments
- ▶ buffer Ø 80 mm

CABIN

- ▶ „cant-off“-system made of galvanized steel, adjustable guide shoes on both sides
- ▶ removable shelf
- ▶ compensation device on suspension ropes / chains
- ▶ safety gear, type tested by TÜV-authorities

BI-PARTING DOORS

- ▶ manual operated bi-parting doors made of galvanized steel in accordance to DIN 18092, production controlled by TÜV-authorities
- ▶ side frames made of galvanized steel according to drawing
- ▶ door locks type-tested by TÜV-authorities

DRIVE UNIT

- ▶ drive unit with factory oil filling, standard motor IP54, disc brake and hand wheel, 3 x 400 V / 50 Hz. according to IEC
- ▶ drum 240 diameter for 2 ropes 5 or 6 mm diameter

CONTROLLER

- ▶ call and send control with 24 V, safety circuit 48 V
- ▶ pre-wired with plugs
- ▶ acoustic arrival signal
- ▶ position indicator on each entrance
- ▶ machine room light with socket

Note: If travel is more than 4 meters, please contact us if drum will fit in the shaft!

LOADING FRONT AND REAR, MACHINE BELOW, WITHOUT SAFETY GEAR

Shaft dimensions are absolute min. plumbed dimensions. The cabin width, depth and height are available in increments of 25 mm. **ATTENTION:** Cabin protection reduces clear entrance openings resp. shaft sizes (please refer to the SKG-OPTIONS)!

Accessible rooms underneath the shaft are not permitted!

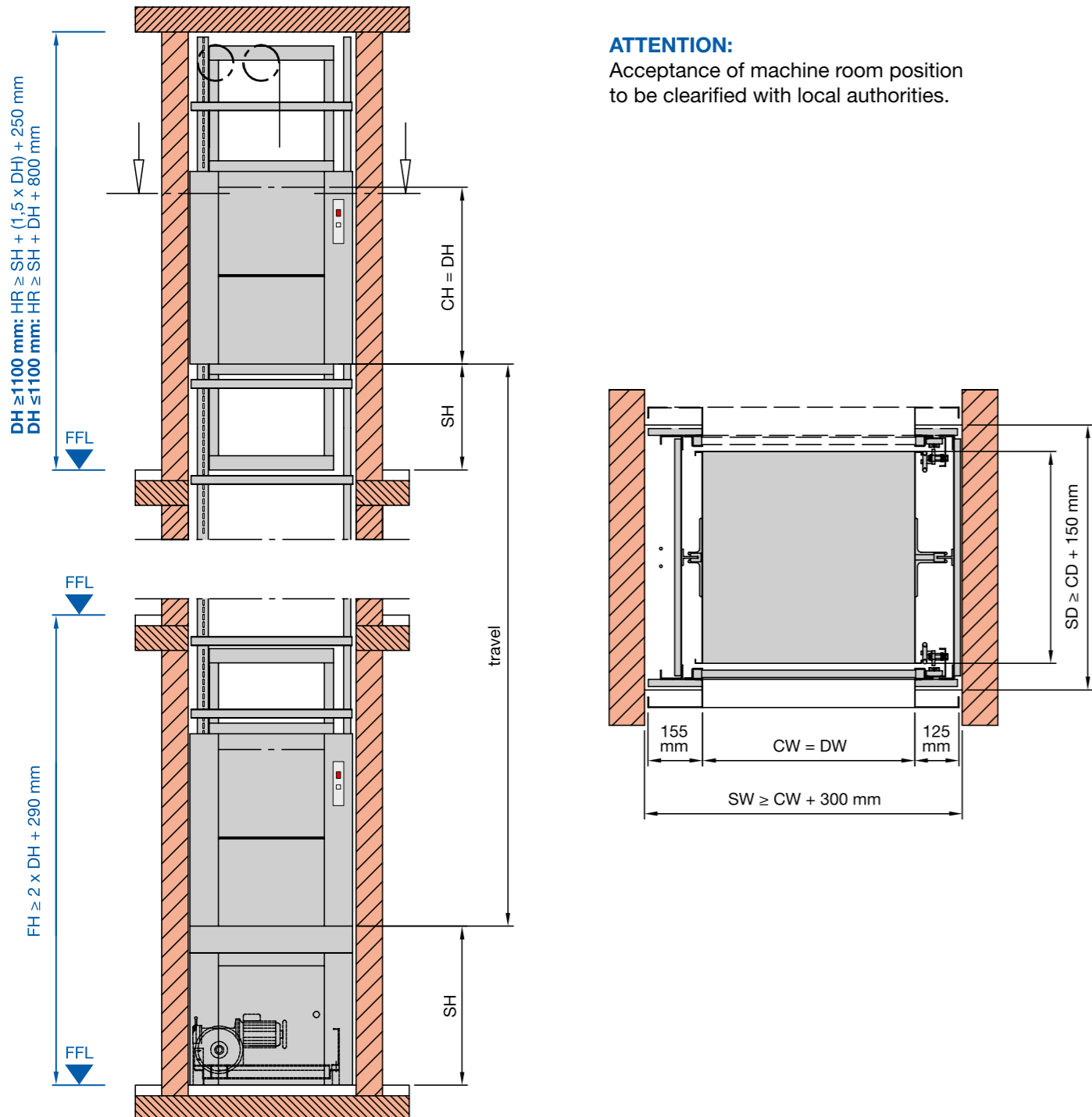

- CW = cabin width = min. 500 to max. 1000 mm
- CD = cabin depth = min. 500 to max. 1000 mm
- CH = cabin height = min. 600 to max. 1200 mm
- DW = door width = cabin width
- DH = door height = cabin height
- SH = serving height = lowest min. 900 mm, others min. 700 mm
- SW = shaft width = plumbed min. dimensions
- SD = shaft depth = plumbed min. dimensions
- HR = headroom = clear height of top floor FFL-underside ceiling
- FFL = finished floor level
- FH = floor to floor height on landing doors in line

LOADING FRONT AND REAR, MACHINE BELOW, WITHOUT SAFETY GEAR

capacity	cabin floor area	speed	2 stops 2 landings	3 stops 3 landings	4 stops 4 landings	5 stops 5 landings	6 stops 6 landings
50 kg	≤ 0,4 m ²	0,3 m/s	5.608,- € A.07.050.04.02	6.644,- € A.07.050.04.03	7.729,- € A.07.050.04.04	8.921,- € A.07.050.04.05	10.292,- € A.07.050.04.06
100 kg	≤ 0,4 m ²	0,3 m/s	5.715,- € A.07.100.04.02	6.751,- € A.07.100.04.03	7.836,- € A.07.100.04.04	9.028,- € A.07.100.04.05	10.400,- € A.07.100.04.06
100 kg	≤ 0,6 m ²	0,3 m/s	5.930,- € A.07.100.06.02	6.967,- € A.07.100.06.03	8.051,- € A.07.100.06.04	9.243,- € A.07.100.06.05	10.614,- € A.07.100.06.06
100 kg	≤ 0,8 m ²	0,3 m/s	6.199,- € A.07.100.08.02	7.234,- € A.07.100.08.03	8.319,- € A.07.100.08.04	9.511,- € A.07.100.08.05	10.883,- € A.07.100.08.06
100 kg	≤ 1,0 m ²	0,3 m/s	6.520,- € A.07.100.10.02	7.557,- € A.07.100.10.03	8.641,- € A.07.100.10.04	9.833,- € A.07.100.10.05	11.204,- € A.07.100.10.06
200 kg	≤ 1,0 m ²	0,15 m/s	Price on request	Price on request	Price on request	Price on request	Price on request
300 kg	≤ 1,0 m ²	0,15 m/s	Price on request	Price on request	Price on request	Price on request	Price on request

from 7 stops and 7 landings prices on request

- ▶ standard complies to EN 81-3 + EU-MRL2006/42/EC
- ▶ 3 meters of travel included for each stop

ATTENTION:

According to EN-81-3 part 8.5 Car entrance, a load protection can be necessary. See extra prices in SKG-OPTIONS on pages 10 and 11.

STANDARD EQUIPMENT AT NO EXTRA-CHARGE

STRUCTURE

- ▶ steel structure, made of cold rolled galvanized special profiles
- ▶ pre-installed with T-guides T 45 x 5 mm and plastic trunking in 2-meter-segments

CABIN

- ▶ „cant-off“-system made of galvanized steel, adjustable guide shoes on both sides
- ▶ removable shelf
- ▶ compensation device on suspension ropes / chains

BI-PARTING DOORS

- ▶ manual operated bi-parting doors made of galvanized steel in accordance to DIN 18092, production controlled by TÜV-authorities
- ▶ side frames made of galvanized steel according to drawing
- ▶ door locks type-tested by TÜV-authorities

MACHINE ROOM DOOR

- ▶ single hinged door (DW ≥ 800 mm = double hinged), with sash lock, both hinging sides available
- ▶ side frames made of galvanized steel according to drawing

DRIVE UNIT

- ▶ drive unit with factory oil filling, standard motor IP54, disc brake and hand wheel, 3 x 400 V / 50 Hz. according to IEC
- ▶ drum 240 diameter for 2 ropes 5 or 6 mm diameter

CONTROLLER

- ▶ call and send control with 24 V, safety circuit 48 V
- ▶ pre-wired with plugs
- ▶ acoustic arrival signal
- ▶ position indicator on each entrance
- ▶ machine room light with socket

Note: If travel is more than 4 meters, please contact us if drum will fit in the shaft!

ADJACENT ENTRANCES, MACHINE ABOVE, **WITHOUT SAFETY GEAR**

Shaft dimensions are absolute min. plumbed dimensions. The cabin width, depth and height are available in increments of 25 mm. **ATTENTION:** Cabin protection reduces clear entrance openings resp. shaft sizes (please refer to the SKG-OPTIONS)!

Accessible rooms underneath the shaft are not permitted!

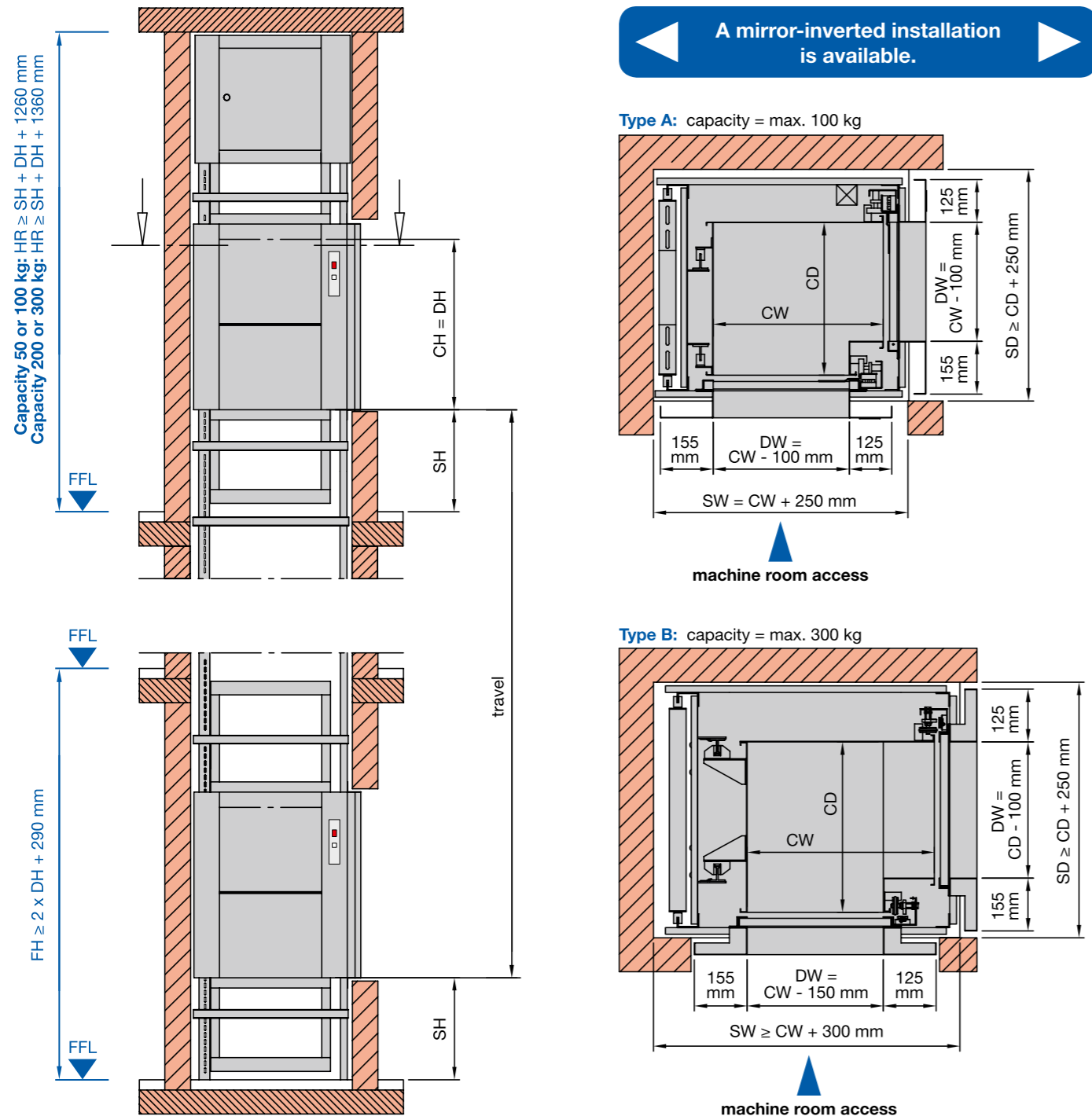

- CW = cabin width
 - CD = cabin depth
 - CH = cabin height
 - DW = door width
 - DH = door height
 - SH = serving height
 - SW = shaft width
 - SD = shaft depth
 - HR = headroom
 - FFL = finished floor level
 - FH = floor to floor height on landing doors in line
- A min. 500 to max. 800 mm
 - A min. 500 to max. 1000 mm
 - A min. 600 to max. 1200 mm
 - = see layouts
 - = cabin height
 - = min. 700 mm
 - = plumbed min. dimensions
 - = plumbed min. dimensions
 - = clear height of top floor FFL-underside ceiling
- B min. 700 to max. 1000 mm
 - B min. 700 to max. 1000 mm
 - B min. 600 to max. 1200 mm

ADJACENT ENTRANCES, MACHINE ABOVE, **WITHOUT SAFETY GEAR**

capacity	cabin floor area	speed	2 stops 2 landings	3 stops 3 landings	4 stops 4 landings	5 stops 5 landings	6 stops 6 landings
50 kg	≤ 0,4 m ²	0,4 m/s	5.098,- € A.09.050.04.02	6.134,- € A.09.050.04.03	7.219,- € A.09.050.04.04	8.410,- € A.09.050.04.05	9.783,- € A.09.050.04.06
100 kg	≤ 0,4 m ²	0,4 m/s	5.313,- € A.09.100.04.02	6.349,- € A.09.100.04.03	7.434,- € A.09.100.04.04	8.626,- € A.09.100.04.05	9.997,- € A.09.100.04.06
100 kg	≤ 0,6 m ²	0,4 m/s	5.528,- € A.09.100.06.02	6.563,- € A.09.100.06.03	7.648,- € A.09.100.06.04	8.840,- € A.09.100.06.05	10.212,- € A.09.100.06.06
100 kg	≤ 0,8 m ²	0,4 m/s	5.796,- € A.09.100.08.02	6.832,- € A.09.100.08.03	7.917,- € A.09.100.08.04	9.109,- € A.09.100.08.05	10.480,- € A.09.100.08.06
100 kg	≤ 1,0 m ²	0,4 m/s	6.118,- € A.09.100.10.02	7.154,- € A.09.100.10.03	8.239,- € A.09.100.10.04	9.431,- € A.09.100.10.05	10.802,- € A.09.100.10.06
200 kg	≤ 1,0 m ²	0,25 m/s	7.326,- € A.09.200.10.02	8.362,- € A.09.200.10.03	9.447,- € A.09.200.10.04	10.638,- € A.09.200.10.05	12.010,- € A.09.200.10.06
300 kg	≤ 1,0 m ²	0,25 m/s	7.379,- € A.09.300.10.02	8.416,- € A.09.300.10.03	9.500,- € A.09.300.10.04	10.692,- € A.09.300.10.05	12.064,- € A.09.300.10.06

from 7 stops and 7 landings prices on request

- ▶ standard complies to EN 81-3 + EU-MRL2006/42/EC
- ▶ 3 meters of travel included for each stop

ATTENTION:

According to EN-81-3 part 8.5 Car entrance, a load protection can be necessary. See extra prices in SKG-OPTIONS on pages 10 and 11.

STANDARD EQUIPMENT AT NO EXTRA-CHARGE

STRUCTURE

- ▶ steel structure, made of cold rolled galvanized special profiles
- ▶ pre-installed with T-guides T 45 x 5 mm and plastic trunking in 2-meter-segments

CABIN

- ▶ „cant-off“-system made of galvanized steel, adjustable guide shoes on both sides
- ▶ removable shelf
- ▶ compensation device on suspension ropes / chains

BI-PARTING DOORS

- ▶ manual operated bi-parting doors made of galvanized steel in accordance to DIN 18092, production controlled by TÜV-authorities
- ▶ side frames made of galvanized steel according to drawing
- ▶ door locks type-tested by TÜV-authorities

MACHINE ROOM DOOR

- ▶ single hinged door (DW ≥ 800 mm = double hinged), with sash lock, both hinging sides available
- ▶ side frames made of galvanized steel according to drawing

DRIVE UNIT

- ▶ drive unit with factory oil filling, standard motor IP54, disc brake and hand wheel, 3 x 400 V / 50 Hz. according to IEC
- ▶ capacity = 50 to 100 kg: sheave Ø 300 diameter for 2 resp. 3 ropes Ø 6 mm
- ▶ capacity = 101 to 300 kg: 2 chain wheels for 2 chains 5/8 x 3/8" DIN 8187

COUNTERWEIGHT OR BALANCE WEIGHT

- ▶ galvanized frame construction with iron infills

CONTROLLER

- ▶ call and send control with 24 V, safety circuit 48 V
- ▶ pre-wired with plugs
- ▶ acoustic arrival signal
- ▶ position indicator on each entrance
- ▶ machine room light with socket

ADJACENT ENTRANCES, MACHINE ABOVE, WITH SAFETY GEAR

Shaft dimensions are absolute min. plumbed dimensions. The cabin width, depth and height are available in increments of 25 mm. **ATTENTION:** Cabin protection reduces clear entrance openings resp. shaft sizes (please refer to the SKG-OPTIONS)!

The shaft bottom must be carried out according to the construction drawing!

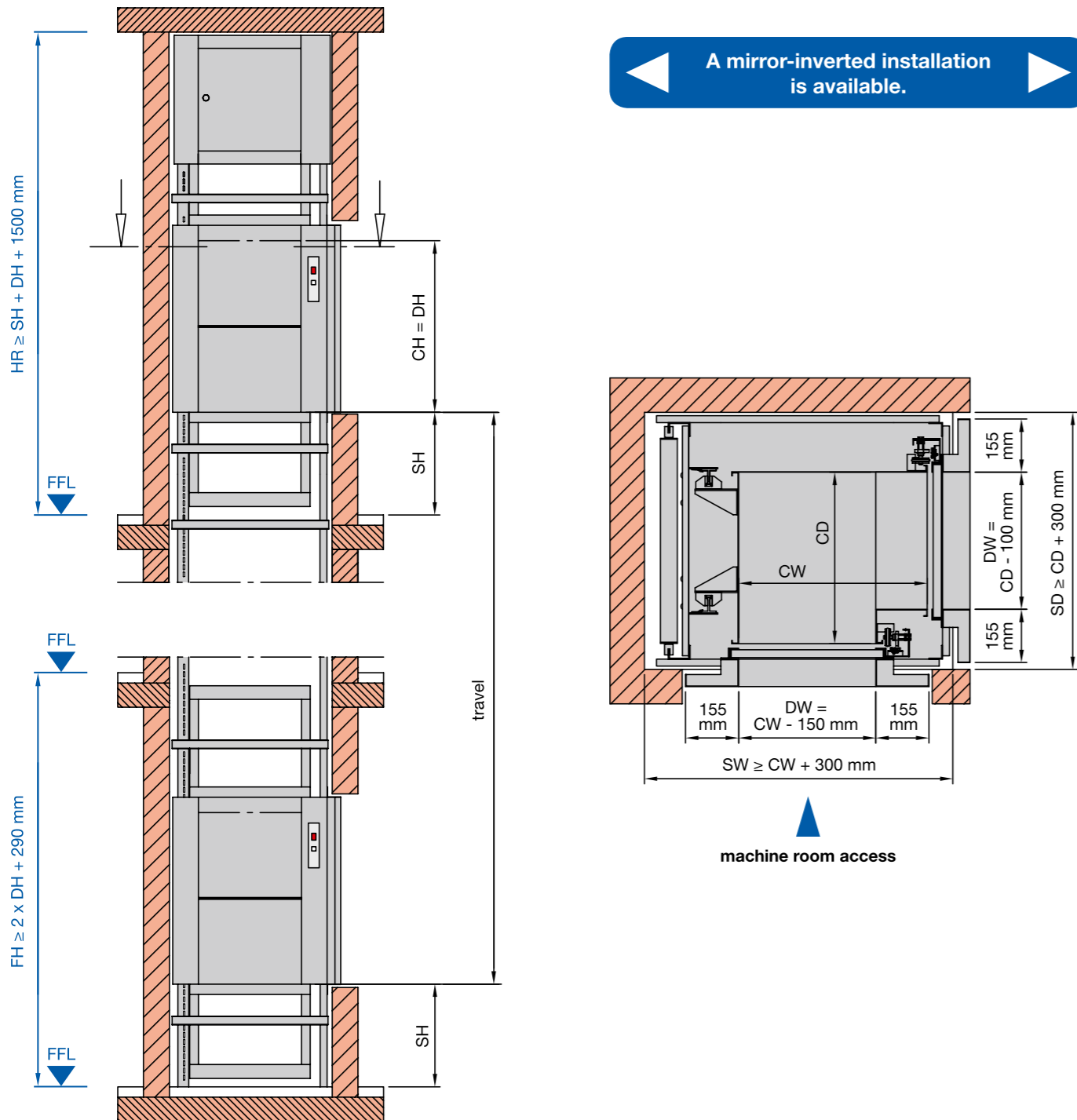

- CW = cabin width = min. 700 to max. 1000 mm
- CD = cabin depth = min. 700 to max. 1000 mm
- CH = cabin height = min. 600 to max. 1200 mm
- DW = door width = cabin width - 150 mm, cabin depth - 100 mm
- DH = door height = cabin height
- SH = serving height = lowest min. 800 mm, others min. 700 mm
- SW = shaft width = plumbed min. dimensions
- SD = shaft depth = plumbed min. dimensions
- HR = headroom = clear height of top floor FFL-underside ceiling
- FFL = finished floor level
- FH = floor to floor height on landing doors in line

ADJACENT ENTRANCES, MACHINE ABOVE, WITH SAFETY GEAR

capacity	cabin floor area	speed	2 stops 2 landings	3 stops 3 landings	4 stops 4 landings	5 stops 5 landings	6 stops 6 landings
50 kg	≤ 0,4 m ²	0,3 m/s	7.748,- € A.10.050.04.02	8.784,- € A.10.050.04.03	9.869,- € A.10.050.04.04	11.061,- € A.10.050.04.05	12.432,- € A.10.050.04.06
100 kg	≤ 0,4 m ²	0,3 m/s	7.855,- € A.10.100.04.02	8.891,- € A.10.100.04.03	9.976,- € A.10.100.04.04	11.168,- € A.10.100.04.05	12.539,- € A.10.100.04.06
100 kg	≤ 0,6 m ²	0,3 m/s	8.070,- € A.10.100.06.02	9.107,- € A.10.100.06.03	10.191,- € A.10.100.06.04	11.383,- € A.10.100.06.05	12.754,- € A.10.100.06.06
100 kg	≤ 0,8 m ²	0,3 m/s	8.339,- € A.10.100.08.02	9.374,- € A.10.100.08.03	10.459,- € A.10.100.08.04	11.651,- € A.10.100.08.05	13.023,- € A.10.100.08.06
100 kg	≤ 1,0 m ²	0,3 m/s	8.268,- € A.10.100.10.02	9.707,- € A.10.100.10.03	10.781,- € A.10.100.10.04	11.973,- € A.10.100.10.05	13.344,- € A.10.100.10.06
200 kg	≤ 1,0 m ²	0,15 m/s	9.707,- € A.10.200.10.02	10.744,- € A.10.200.10.03	11.828,- € A.10.200.10.04	13.020,- € A.10.200.10.05	14.391,- € A.10.200.10.06
300 kg	≤ 1,0 m ²	0,15 m/s	9.895,- € A.10.300.10.02	10.932,- € A.10.300.10.03	12.016,- € A.10.300.10.04	13.208,- € A.10.300.10.05	14.579,- € A.10.300.10.06

from 7 stops and 7 landings prices on request

- ▶ standard complies to EN 81-3 + EU-MRL2006/42/EC
- ▶ 3 meters of travel included for each stop

ATTENTION:

According to EN-81-3 part 8.5 Car entrance, a load protection can be necessary. See extra prices in SKG-OPTIONS on pages 10 and 11.

STANDARD EQUIPMENT AT NO EXTRA-CHARGE

STRUCTURE

- ▶ steel structure, made of cold rolled galvanized special profiles
- ▶ pre-installed with T-guides T 45 x 5 mm and plastic trunking in 2-meter-segments
- ▶ buffer Ø 80 mm

CABIN

- ▶ „cant-off“-system made of galvanized steel, adjustable guide shoes on both sides
- ▶ removable shelf
- ▶ compensation device on suspension ropes / chains
- ▶ safety gear, type tested by TÜV-authorities

BI-PARTING DOORS

- ▶ manual operated bi-parting doors made of galvanized steel in accordance to DIN 18092, production controlled by TÜV-authorities
- ▶ side frames made of galvanized steel according to drawing
- ▶ door locks type-tested by TÜV-authorities

MACHINE ROOM DOOR

- ▶ single hinged door (DW ≥ 800 mm = double hinged), with sash lock, both hinging sides available
- ▶ side frames made of galvanized steel according to drawing

DRIVE UNIT

- ▶ drive unit with factory oil filling, standard motor IP54, disc brake and hand wheel, 3 x 400 V / 50 Hz. according to IEC
- ▶ drum 240 diameter for 2 ropes 5 oder 6 mm diameter

CONTROLLER

- ▶ call and send control with 24 V, safety circuit 48 V
- ▶ pre-wired with plugs
- ▶ acoustic arrival signal
- ▶ position indicator on each entrance
- ▶ machine room light with socket

Note: If travel is more than 4 meters, please contact us if drum will fit in the shaft!

3-SIDES ADJACENT ENTRANCES, MACHINE ABOVE, WITHOUT SAFETY GEAR

Shaft dimensions are absolute min. plumbed dimensions. The cabin width, depth and height are available in increments of 25 mm. **ATTENTION:** Cabin protection reduces clear entrance openings resp. shaft sizes (please refer to the SKG-OPTIONS)!

Accessible rooms underneath the shaft are not permitted!

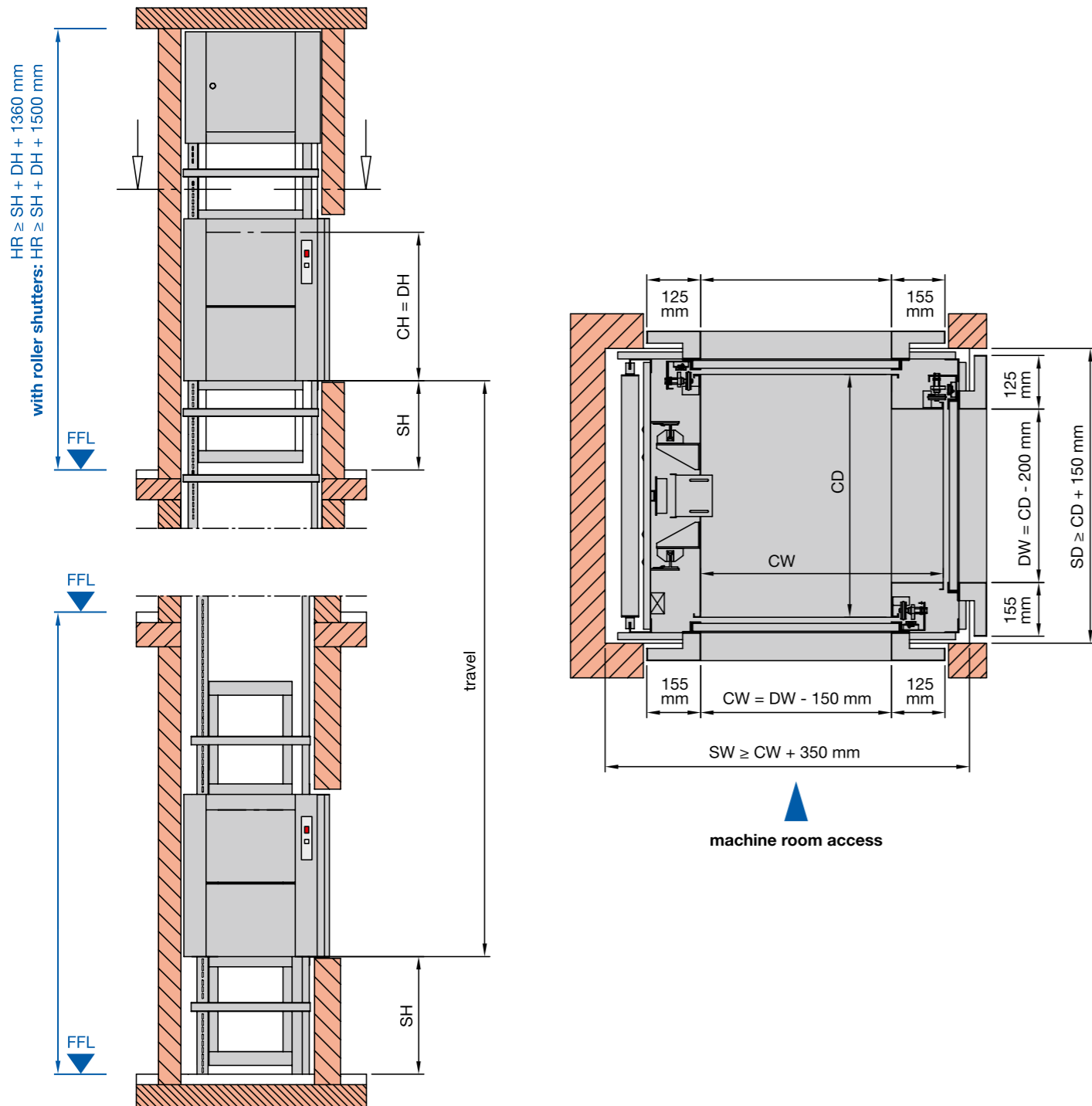

- CW = cabin width min. 600 to max. 1000 mm
- CD = cabin depth min. 700 to max. 1000 mm
- CH = cabin height min. 600 to max. 1200 mm
- DW = door width = cabin width -150 mm, cabin depth -200 mm
- DH = door height = cabin height
- SH = serving height = min. 700 mm
- SW = shaft width = plumbed min. dimensions
- SD = shaft depth = plumbed min. dimensions
- HR = headroom = clear height of top floor FFL-underside ceiling
- FFL = finished floor level

3-SIDES ADJACENT ENTRANCES, MACHINE ABOVE, WITHOUT SAFETY GEAR

capacity	cabin floor area	speed	2 stops 3 landings	3 stops 3 landings	4 stops 4 landings	5 stops 5 landings	6 stops 6 landings
50 kg	≤ 0,4 m ²	0,4 m/s	5.485,- € A.17.050.04.02	6.134,- € A.17.050.04.03	7.219,- € A.17.050.04.04	8.410,- € A.17.050.04.05	9.783,- € A.17.050.04.06
100 kg	≤ 0,4 m ²	0,4 m/s	5.700,- € A.17.100.04.02	6.349,- € A.17.100.04.03	7.434,- € A.17.100.04.04	8.626,- € A.17.100.04.05	9.997,- € A.17.100.04.06
100 kg	≤ 0,6 m ²	0,4 m/s	5.915,- € A.17.100.06.02	6.563,- € A.17.100.06.03	7.648,- € A.17.100.06.04	8.840,- € A.17.100.06.05	10.212,- € A.17.100.06.06
100 kg	≤ 0,8 m ²	0,4 m/s	6.183,- € A.17.100.08.02	6.832,- € A.17.100.08.03	7.917,- € A.17.100.08.04	9.109,- € A.17.100.08.05	10.480,- € A.17.100.08.06
100 kg	≤ 1,0 m ²	0,4 m/s	6.505,- € A.17.100.10.02	7.154,- € A.17.100.10.03	8.239,- € A.17.100.10.04	9.431,- € A.17.100.10.05	10.802,- € A.17.100.10.06
200 kg	≤ 1,0 m ²	0,25 m/s	Price on request	Price on request	Price on request	Price on request	Price on request
300 kg	≤ 1,0 m ²	0,25 m/s	Price on request	Price on request	Price on request	Price on request	Price on request

from 7 stops and 7 landings prices on request

- ▶ standard complies to EN 81-3 + EU-MRL2006/42/EC
- ▶ 3 meters of travel included for each stop

ATTENTION:

According to EN-81-3 part 8.5 Car entrance, a load protection can be necessary. See extra prices in SKG-OPTIONS on pages 10 and 11.

STANDARD EQUIPMENT AT NO EXTRA-CHARGE

STRUCTURE

- ▶ steel structure, made of cold rolled galvanized special profiles
- ▶ pre-installed with T-guides T 45 x 5 mm and plastic trunking in 2-meter-segments

CABIN

- ▶ „cant-off“-system made of galvanized steel, adjustable guide shoes on both sides
- ▶ removable shelf
- ▶ compensation device on suspension ropes / chains

BI-PARTING DOORS

- ▶ manual operated bi-parting doors made of galvanized steel in accordance to DIN 18092, production controlled by TÜV-authorities
- ▶ side frames made of galvanized steel according to drawing
- ▶ door locks type-tested by TÜV-authorities

MACHINE ROOM DOOR

- ▶ single hinged door (DW ≥ 800 mm = double hinged), with sash lock, both hinging sides available
- ▶ side frames made of galvanized steel according to drawing

DRIVE UNIT

- ▶ drive unit with factory oil filling, standard motor IP54, disc brake and hand wheel, 3 x 400 V / 50 Hz. according to IEC
- ▶ capacity = 50 to 100 kg: sheave Ø 300 diameter for 2 ropes Ø 6 mm
- ▶ capacity = 101 to 300 kg: 2 chain wheels for 2 chains 5/8 x 3/8" DIN 8187

COUNTERWEIGHT OR BALANCE WEIGHT

- ▶ galvanized frame construction with iron infills

CONTROLLER

- ▶ call and send control with 24 V, safety circuit 48 V
- ▶ pre-wired with plugs
- ▶ acoustic arrival signal
- ▶ position indicator on each entrance
- ▶ machine room light with socket

SKG

SERVICE LIFTS

BI-PARTING DOORS SERVING AT FLOOR LEVEL ▶▶



ISO-C

LOADING FRONT AND REAR, MACHINE ABOVE, **WITHOUT SAFETY GEAR**

Shaft dimensions are absolute min. plumbed dimensions. The cabin width, depth and height are available in increments of 25 mm. **ATTENTION:** Cabin protection reduces clear entrance openings resp. shaft sizes (please refer to the SKG-OPTIONS)!

Accessible rooms underneath the shaft are not permitted!

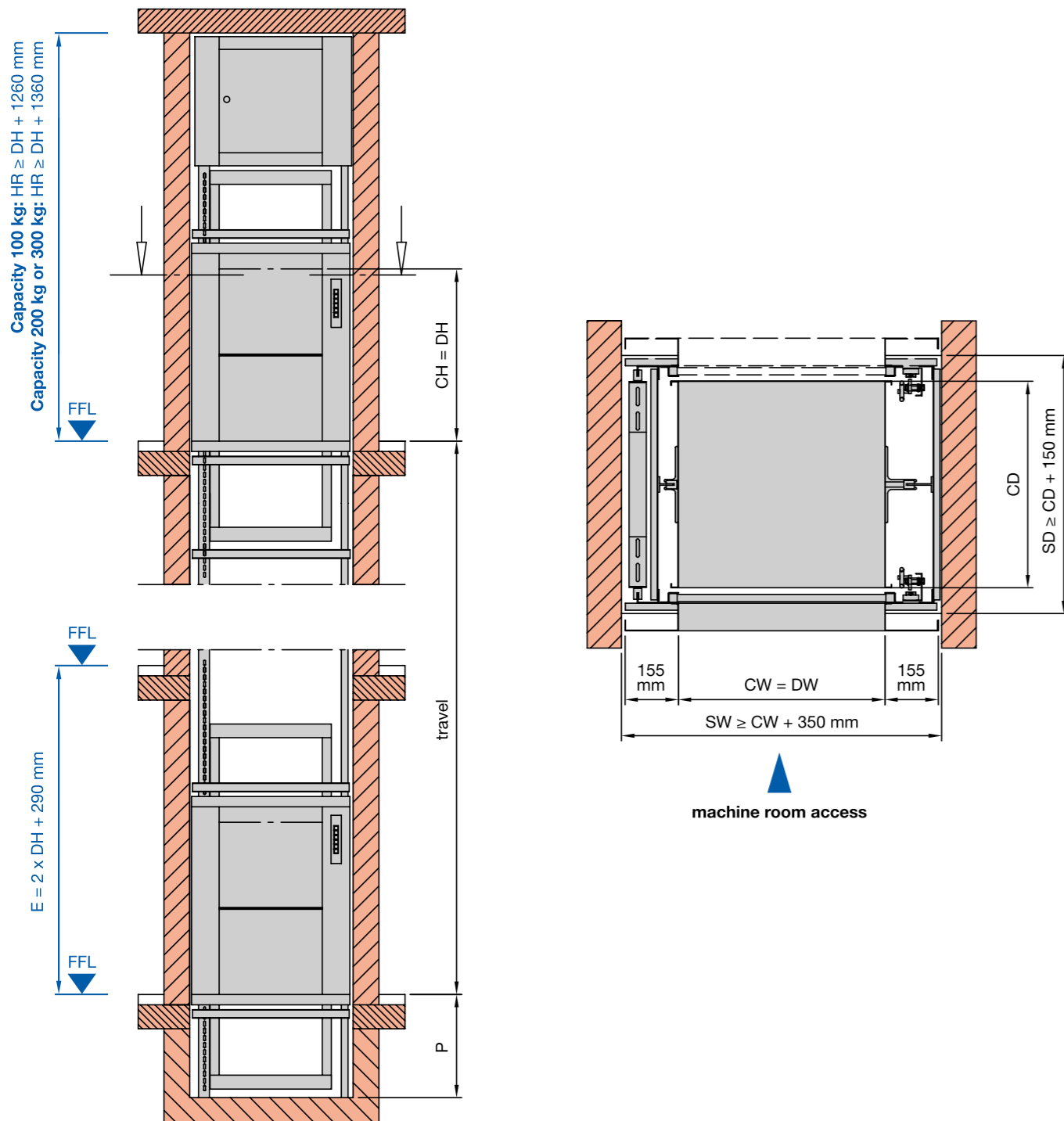

CW	=	cabin width	min. 500 to max. 1000 mm
CD	=	cabin depth	min. 600 to max. 1000 mm
CH	=	cabin height	min. 800 to max. 1200 mm
DW	=	door width	= cabin width
DH	=	door height	= cabin height
P	=	pit	= min. door height / 2 + 50 mm
SW	=	shaft width	= plumbed min. dimensions
SD	=	shaft depth	= plumbed min. dimensions
HR	=	headroom	= clear height of top floor FFL-underside ceiling
FFL	=	finished floor level	
FH	=	floor to floor height on landing doors in line	

LOADING FRONT AND REAR, MACHINE ABOVE, **WITHOUT SAFETY GEAR**

capacity	cabin floor area	speed	2 stops 2 landings	3 stops 3 landings	4 stops 4 landings	5 stops 5 landings	6 stops 6 landings
100 kg	≤ 1 m ²	0,27 m/s	5.796,- € C.01.100.10.02	7.164,- € C.01.100.10.03	8.560,- € C.01.100.10.04	10.118,- € C.01.100.10.05	11.997,- € C.01.100.10.06
200 kg	≤ 1 m ²	0,25 m/s	6.065,- € C.01.200.10.02	7.434,- € C.01.200.10.03	8.829,- € C.01.200.10.04	10.386,- € C.01.200.10.05	12.265,- € C.01.200.10.06
300 kg	≤ 1 m ²	0,25 m/s	6.091,- € C.01.300.10.02	7.460,- € C.01.300.10.03	8.857,- € C.01.300.10.04	10.413,- € C.01.300.10.05	12.292,- € C.01.300.10.06

from 7 stops and 7 landings prices on request

- ▶ standard complies to EN 81-3 + EU-MRL2006/42/EC
- ▶ 3 meters of travel included for each stop

ATTENTION:

According to EN-81-3 part 8.5 Car entrance, a load protection can be necessary. See extra prices in SKG-OPTIONS on pages 10 and 11.

STANDARD EQUIPMENT AT NO EXTRA-CHARGE

STRUCTURE

- ▶ steel structure, made of cold rolled galvanized special profiles
- ▶ pre-installed with T-guides T 45 x 5 mm and plastic trunking in 2-meter-segments

CABIN

- ▶ „cant-off“-system made of galvanized steel, adjustable guide shoes on both sides
- ▶ removable shelf
- ▶ compensation device on suspension ropes / chains

BI-PARTING DOORS

- ▶ manual operated bi-parting doors made of galvanized steel in accordance to DIN 18092, production controlled by TÜV-authorities
- ▶ side frames made of galvanized steel according to drawing
- ▶ door locks type-tested by TÜV-authorities

MACHINE ROOM DOOR

- ▶ single hinged door (DW ≥ 800 mm = double hinged), with sash lock, both hinging sides available
- ▶ side frames made of galvanized steel according to drawing

DRIVE UNIT

- ▶ drive unit with factory oil filling, standard motor IP54, disc brake and hand wheel, 3 x 400 V / 50 Hz. according to IEC
- ▶ capacity = 100 kg: sheave Ø 300 diameter for 2 resp. 3 ropes Ø 6 mm
- ▶ capacity = 200 or 300 kg: 2 chain wheels for 2 chains 5/8 x 3/8“ DIN 8187

COUNTERWEIGHT OR BALANCE WEIGHT

- ▶ galvanized frame construction with iron infills

CONTROLLER

- ▶ call and send control with 24 V, safety circuit 48 V
- ▶ pre-wired with plugs
- ▶ acoustic arrival signal
- ▶ position indicator on each entrance
- ▶ machine room light with socket

LOADING FRONT AND REAR, MACHINE ABOVE, WITH SAFETY GEAR

Shaft dimensions are absolute min. plumbed dimensions. The cabin width, depth and height are available in increments of 25 mm. **ATTENTION:** Cabin protection reduces clear entrance openings resp. shaft sizes (please refer to the SKG-OPTIONS)!

The shaft bottom must be carried out according to the construction drawing!

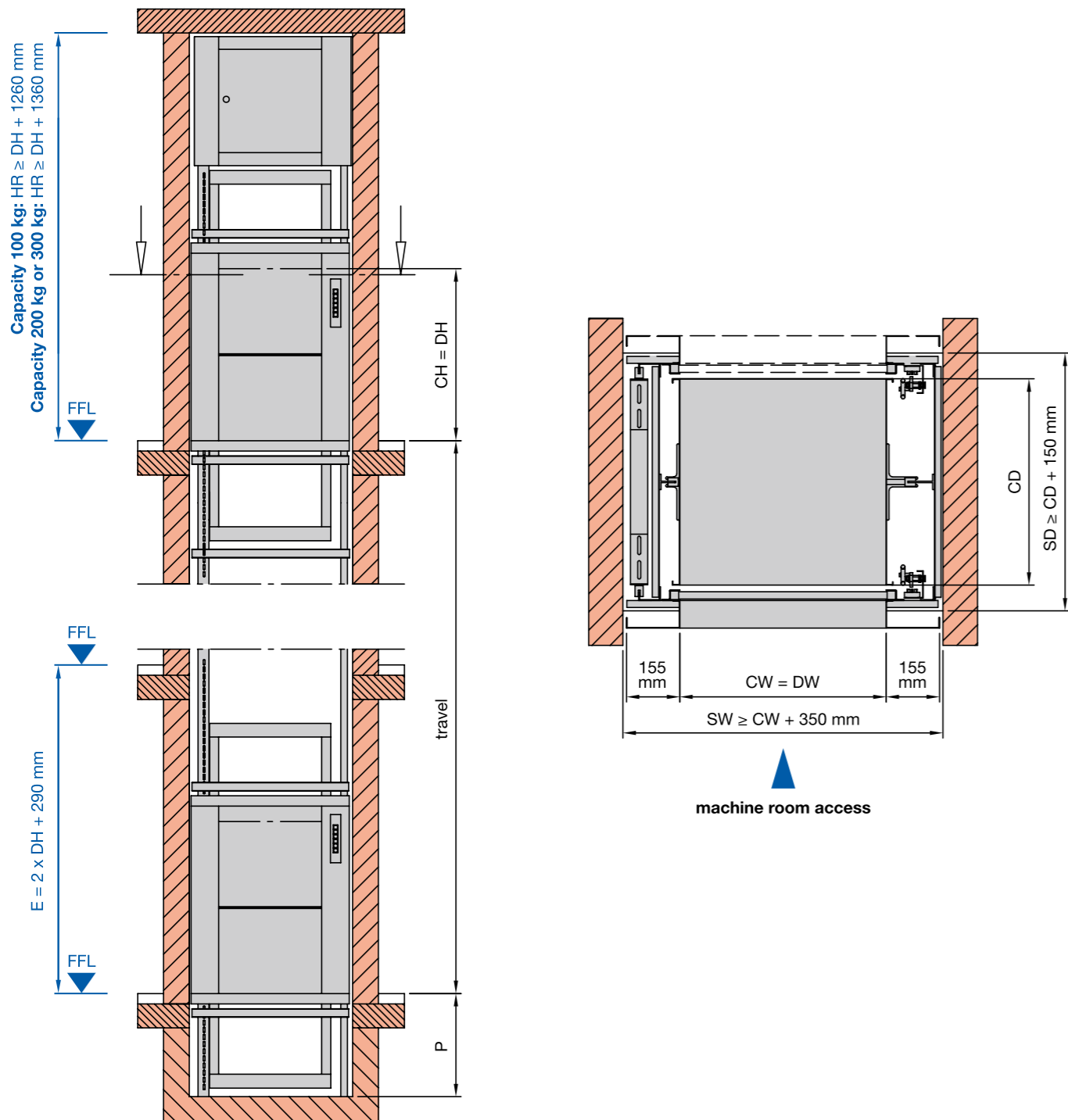

- CW = cabin width = min. 600 to max. 1000 mm
- CD = cabin depth = min. 700 to max. 1000 mm
- CH = cabin height = min. 800 to max. 1200 mm
- DW = door width = cabin width
- DH = door height = cabin height
- P = pit = min. door height / 2 + 50 mm
- SW = shaft width = plumbed min. dimensions
- SD = shaft depth = plumbed min. dimensions
- HR = headroom = clear height of top floor FFL-underside ceiling
- FFL = finished floor level
- FH = floor to floor height on landing doors in line

LOADING FRONT AND REAR, MACHINE ABOVE, WITH SAFETY GEAR

capacity	cabin floor area	speed	2 stops 2 landings	3 stops 3 landings	4 stops 4 landings	5 stops 5 landings	6 stops 6 landings
100 kg	≤ 1 m ²	0,15 m/s	9.252,- € C.02.100.10.02	10.621,- € C.02.100.10.03	12.016,- € C.02.100.10.04	13.573,- € C.02.100.10.05	15.452,- € C.02.100.10.06
200 kg	≤ 1 m ²	0,15 m/s	9.681,- € C.02.200.10.02	11.050,- € C.02.200.10.03	12.446,- € C.02.200.10.04	14.003,- € C.02.200.10.05	15.881,- € C.02.200.10.06
300 kg	≤ 1 m ²	0,15 m/s	9.788,- € C.02.300.10.02	11.157,- € C.02.300.10.03	12.553,- € C.02.300.10.04	14.110,- € C.02.300.10.05	15.988,- € C.02.300.10.06

from 7 stops and 7 landings prices on request

- ▶ standard complies to EN 81-3 + EU-MRL2006/42/EC
- ▶ 3 meters of travel included for each stop

ATTENTION:

According to EN-81-3 part 8.5 Car entrance, a load protection can be necessary. See extra prices in SKG-OPTIONS on pages 10 and 11.

STANDARD EQUIPMENT AT NO EXTRA-CHARGE

STRUCTURE

- ▶ steel structure, made of cold rolled galvanized special profiles
- ▶ pre-installed with T-guides T 45 x 5 mm and plastic trunking in 2-meter-segments
- ▶ buffer Ø 80 mm

CABIN

- ▶ „cant-off“-system made of galvanized steel, adjustable guide shoes on both sides
- ▶ removable shelf
- ▶ compensation device on suspension ropes / chains
- ▶ safety gear, type tested by TÜV-authorities

BI-PARTING DOORS

- ▶ manual operated bi-parting doors made of galvanized steel in accordance to DIN 18092, production controlled by TÜV-authorities
- ▶ side frames made of galvanized steel according to drawing
- ▶ door locks type-tested by TÜV-authorities

MACHINE ROOM DOOR

- ▶ single hinged door (DW ≥ 800 mm = double hinged), with sash lock, both hinging sides available
- ▶ side frames made of galvanized steel according to drawing

DRIVE UNIT

- ▶ drive unit with factory oil filling, standard motor IP54, disc brake and hand wheel, 3 x 400 V / 50 Hz. according to IEC
- ▶ drum 240 diameter for 2 ropes 5 or 6 mm diameter

CONTROLLER

- ▶ call and send control with 24 V, safety circuit 48 V
- ▶ pre-wired with plugs
- ▶ adjustable and time-limited despatch delay device (1-5 s)
- ▶ acoustic arrival signal
- ▶ position indicator on each entrance
- ▶ thermic motor protection as main switch pre-wired on control panel
- ▶ machine room light with socket

Note: If travel is more than 4 meters, please contact us if drum will fit in the shaft!

SERVICE LIFTS HINGED DOORS SERVING AT FLOOR LEVEL ▶▶



ISO-D
ISO-U

LOADING FRONT AND REAR, MACHINE ABOVE, **WITHOUT SAFETY GEAR**

Shaft dimensions are absolute min. plumbed dimensions. The cabin width, depth and height are available in increments of 25 mm. **ATTENTION:** Cabin protection reduces clear entrance openings resp. shaft sizes (please refer to the SKG-OPTIONS)!

Accessible rooms underneath the shaft are not permitted!

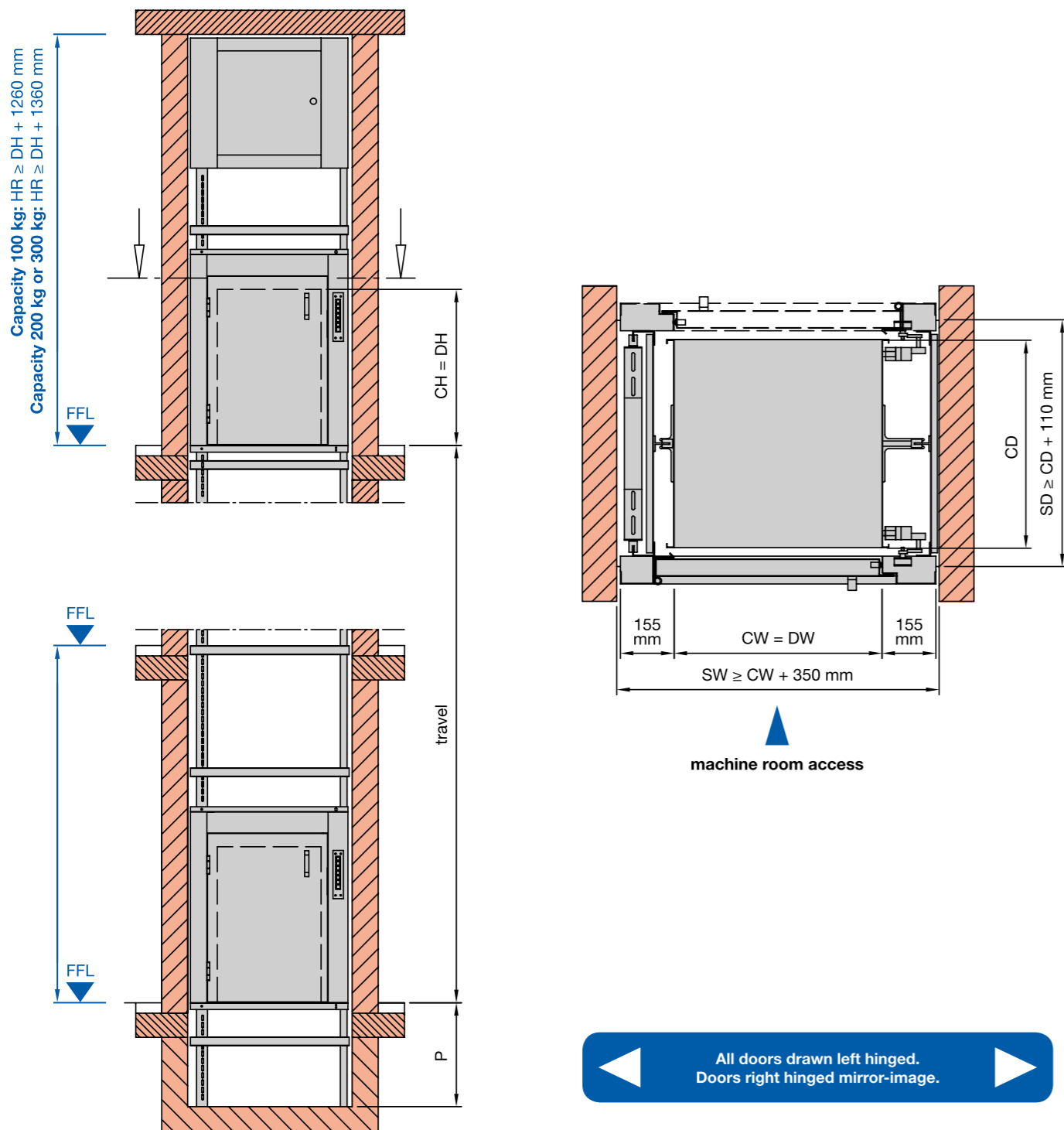

CW	=	cabin width	=	min. 500 to max. 1000 mm
CD	=	cabin depth	=	min. 600 to max. 1000 mm
CH	=	cabin height	=	min. 800 to max. 1200 mm
DW	=	door width	=	cabin width
DH	=	door height	=	cabin height
P	=	pit	=	min. 250 mm
SW	=	shaft width	=	plumbed min. dimensions
SD	=	shaft depth	=	plumbed min. dimensions
HR	=	headroom	=	clear height of top floor FFL-underside ceiling
FFL	=	finished floor level		

LOADING FRONT AND REAR, MACHINE ABOVE, **WITHOUT SAFETY GEAR**

capacity	cabin floor area	speed	2 stops 2 landings	3 stops 3 landings	4 stops 4 landings	5 stops 5 landings	6 stops 6 landings
100 kg	≤ 1 m ²	0,27 m/s	6.011,- € D.01.100.10.02	7.379,- € D.01.100.10.03	8.776,- € D.01.100.10.04	10.333,- € D.01.100.10.05	12.211,- € D.01.100.10.06
200 kg	≤ 1 m ²	0,25 m/s	6.279,- € D.01.200.10.02	7.648,- € D.01.200.10.03	9.044,- € D.01.200.10.04	10.601,- € D.01.200.10.05	12.480,- € D.01.200.10.06
300 kg	≤ 1 m ²	0,25 m/s	6.308,- € D.01.300.10.02	7.675,- € D.01.300.10.03	9.071,- € D.01.300.10.04	10.628,- € D.01.300.10.05	12.506,- € D.01.300.10.06

from 7 stops and 7 landings prices on request

- ▶ standard complies to EN 81-3 + EU-MRL2006/42/EC
- ▶ 3 meters of travel included for each stop

ATTENTION:

According to EN-81-3 part 8.5 Car entrance, a load protection can be necessary. See extra prices in SKG-OPTIONS on pages 10 and 11.

STANDARD EQUIPMENT AT NO EXTRA-CHARGE

STRUCTURE

- ▶ steel structure, made of cold rolled galvanized special profiles
- ▶ pre-installed with T-guides T 45 x 5 mm and plastic trunking in 2-meter-segments

CABIN

- ▶ „cant-off“-system made of galvanized steel, adjustable guide shoes on both sides
- ▶ compensation device on suspension ropes / chains

HINGED DOORS

- ▶ manual operated hinged doors, made of galvanized steel in accordance to DIN 18090, production controlled by TÜV-authorities
- ▶ side frames made of galvanized steel according to drawing
- ▶ door locks type-tested by TÜV-authorities

MACHINE ROOM DOOR

- ▶ single hinged door (DW ≥ 800 mm = double hinged), with sash lock, both hinging sides available
- ▶ side frames made of galvanized steel according to drawing

DRIVE UNIT

- ▶ drive unit with factory oil filling, standard motor IP54, disc brake and hand wheel, 3 x 400 V / 50 Hz. according to IEC
- ▶ capacity = 100 kg: sheave Ø 300 diameter for 2 resp. 3 ropes Ø 6 mm
- ▶ capacity = 200 or 300 kg: 2 chain wheels for 2 chains 5/8 x 3/8" DIN 8187

COUNTERWEIGHT OR BALANCE WEIGHT

- ▶ galvanized frame construction with iron infills

CONTROLLER

- ▶ call and send control with 24 V, safety circuit 48 V
- ▶ pre-wired with plugs
- ▶ acoustic arrival signal
- ▶ position indicator on each entrance
- ▶ machine room light with socket

LOADING FRONT AND REAR, MACHINE ABOVE, WITH SAFETY GEAR

Shaft dimensions are absolute min. plumbed dimensions. The cabin width, depth and height are available in increments of 25 mm. **ATTENTION:** Cabin protection reduces clear entrance openings resp. shaft sizes (please refer to the SKG-OPTIONS)!

The shaft bottom must be carried out according to the construction drawing!

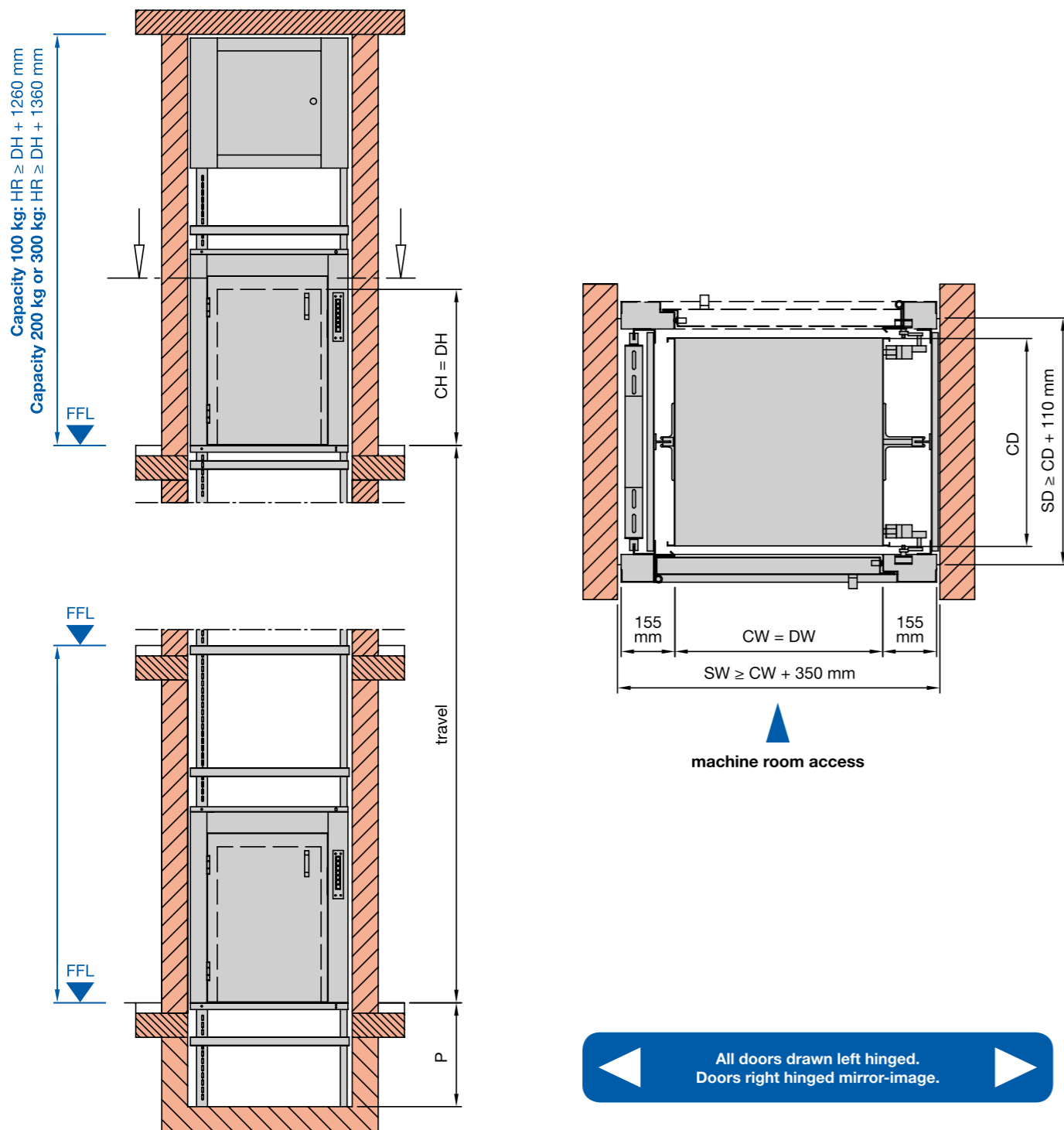

CW	=	cabin width	min. 600 to max. 1000 mm
CD	=	cabin depth	min. 700 to max. 1000 mm
CH	=	cabin height	min. 800 to max. 1200 mm
DW	=	door width	= cabin width
DH	=	door height	= cabin height
P	=	pit	min. 250 mm
SW	=	shaft width	= plumbed min. dimensions
SD	=	shaft depth	= plumbed min. dimensions
HR	=	headroom	= clear height of top floor FFL-underside ceiling
FFL	=	finished floor level	

LOADING FRONT AND REAR, MACHINE ABOVE, WITH SAFETY GEAR

capacity	cabin floor area	speed	2 stops 2 landings	3 stops 3 landings	4 stops 4 landings	5 stops 5 landings	6 stops 6 landings
100 kg	≤ 1 m ²	0,15 m/s	9.365,- € D.02.100.10.02	10.730,- € D.02.100.10.03	12.135,- € D.02.100.10.04	13.680,- € D.02.100.10.05	15.560,- € D.02.100.10.06
200 kg	≤ 1 m ²	0,15 m/s	9.795,- € D.02.200.10.02	11.164,- € D.02.200.10.03	12.560,- € D.02.200.10.04	14.116,- € D.02.200.10.05	15.676,- € D.02.200.10.06
300 kg	≤ 1 m ²	0,15 m/s	9.902,- € D.02.300.10.02	11.276,- € D.02.300.10.03	12.665,- € D.02.300.10.04	14.224,- € D.02.300.10.05	16.100,- € D.02.300.10.06

from 7 stops and 7 landings prices on request

- ▶ standard complies to EN 81-3 + EU-MRL2006/42/EC
- ▶ 3 meters of travel included for each stop

ATTENTION:

According to EN-81-3 part 8.5 Car entrance, a load protection can be necessary. See extra prices in SKG-OPTIONS on pages 10 and 11.

STANDARD EQUIPMENT AT NO EXTRA-CHARGE

STRUCTURE

- ▶ steel structure, made of cold rolled galvanized special profiles
- ▶ pre-installed with T-guides T 45 x 5 mm and plastic trunking in 2-meter-segments
- ▶ buffer Ø 80 mm

CABIN

- ▶ „cant-off“-system made of galvanized steel, adjustable guide shoes on both sides
- ▶ compensation device on suspension ropes / chains
- ▶ safety gear, type tested by TÜV-authorities

HINGED DOORS

- ▶ manual operated hinged doors, made of galvanized steel in accordance to DIN 18090, production controlled by TÜV-authorities
- ▶ side frames made of galvanized steel according to drawing
- ▶ door locks type-tested by TÜV-authorities

MACHINE ROOM DOOR

- ▶ single hinged door (DW ≥ 800 mm = double hinged), with sash lock, both hinging sides available
- ▶ side frames made of galvanized steel according to drawing

DRIVE UNIT

- ▶ drive unit with factory oil filling, standard motor IP54, disc brake and hand wheel, 3 x 400 V / 50 Hz. according to IEC
- ▶ drum Ø 240 mm and pulleys Ø 250 resp. 200 mm for 2 ropes Ø 6 resp. 5 mm suspension 2:1

CONTROLLER

- ▶ call and send control with 24 V, safety circuit 48 V
- ▶ pre-wired with plugs
- ▶ acoustic arrival signal
- ▶ position indicator on each entrance
- ▶ machine room light with socket

Note: If travel is more than 4 meters, please contact us if drum will fit in the shaft!

LOADING FRONT AND REAR, MACHINE SIDE ABOVE, **WITHOUT SAFETY GEAR**

Shaft dimensions are absolute min. plumbed dimensions. The cabin width, depth and height are available in increments of 25 mm. **ATTENTION:** Cabin protection reduces clear entrance openings resp. shaft sizes (please refer to the SKG-OPTIONS)!

Accessible rooms underneath the shaft are not permitted!

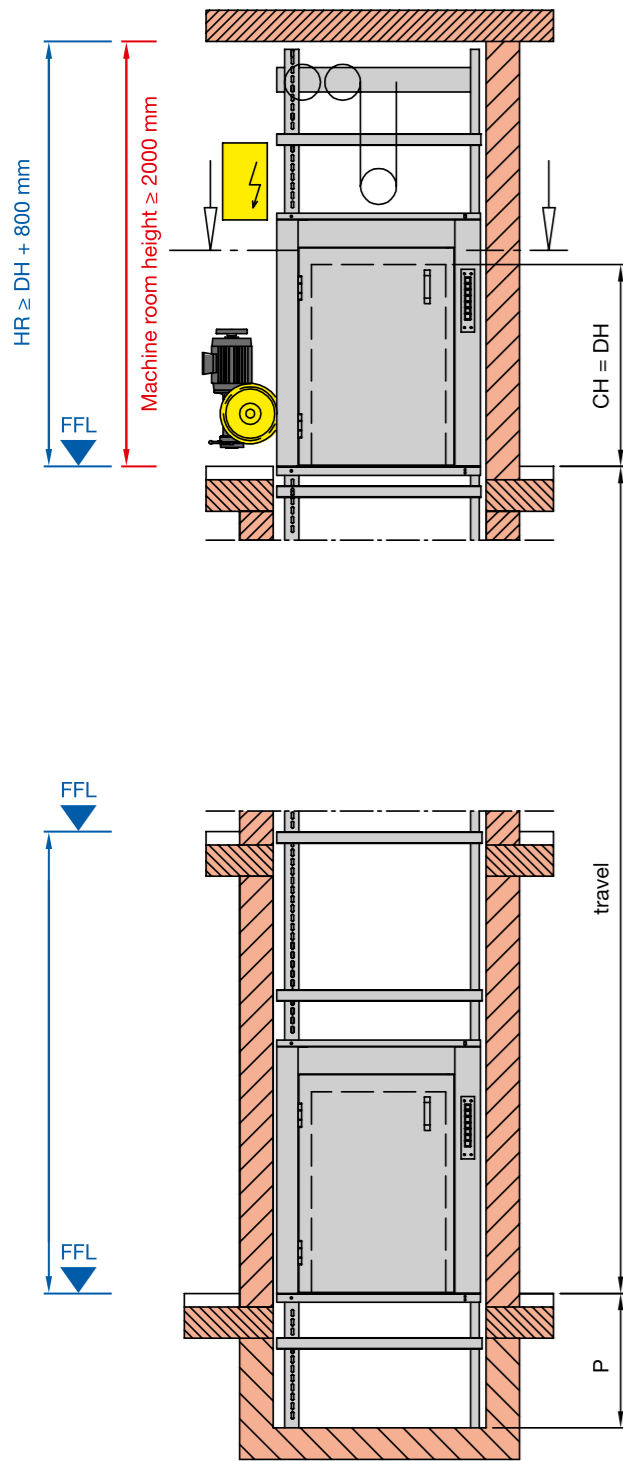

ATTENTION: Machine room door by others!
Please indicate the position of the machine room (left or right) to be advised in relation to the upper landing door!

Machine room width = shaft depth

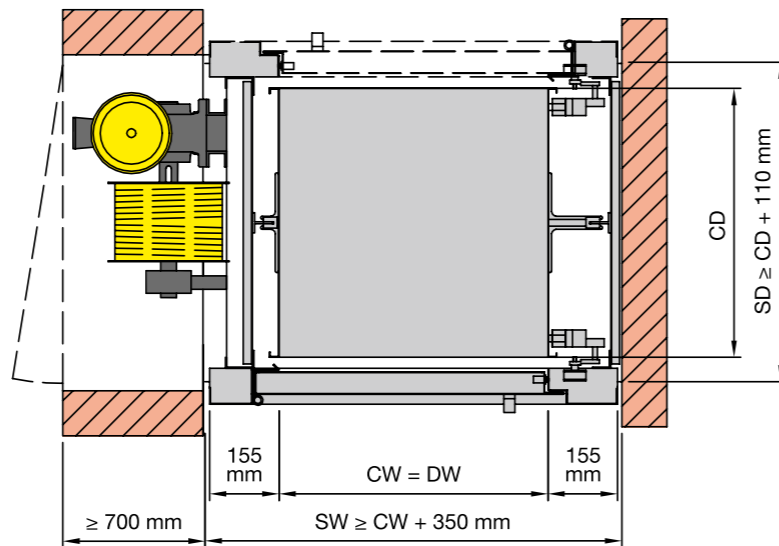

◀ All doors drawn left hinged. Doors right hinged mirror-image. ▶

- CW = cabin width = min. 500 to max. 1000 mm
- CD = cabin depth = min. 650 to max. 1000 mm
- CH = cabin height = min. 800 to max. 1200 mm
- DW = door width = cabin width
- DH = door height = cabin height
- P = pit = min. 250 mm
- SW = shaft width = plumbed min. dimensions
- SD = shaft depth = plumbed min. dimensions
- HR = headroom = clear height of top floor FFL-underside ceiling
- FFL = finished floor level

LOADING FRONT AND REAR, MACHINE SIDE ABOVE, **WITHOUT SAFETY GEAR**

capacity	cabin floor area	speed	2 stops 2 landings	3 stops 3 landings	4 stops 4 landings	5 stops 5 landings	6 stops 6 landings
100 kg	≤ 1 m ²	0,15 m/s	7.460,- € D.03.100.10.02	8.829,- € D.03.100.10.03	10.225,- € D.03.100.10.04	11.782,- € D.03.100.10.05	13.661,- € D.03.100.10.06
200 kg	≤ 1 m ²	0,15 m/s	8.507,- € D.03.200.10.02	9.876,- € D.03.200.10.03	11.272,- € D.03.200.10.04	12.829,- € D.03.200.10.05	14.708,- € D.03.200.10.06
300 kg	≤ 1 m ²	0,15 m/s	8.910,- € D.03.300.10.02	10.278,- € D.03.300.10.03	11.675,- € D.03.300.10.04	13.232,- € D.03.300.10.05	15.110,- € D.03.300.10.06

from 7 stops and 7 landings prices on request

- ▶ standard complies to EN 81-3 + EU-MRL2006/42/EC
- ▶ 3 meters of travel included for each stop

ATTENTION:
According to EN-81-3 part 8.5 Car entrance, a load protection can be necessary. See extra prices in SKG-OPTIONS on pages 10 and 11.

STANDARD EQUIPMENT AT NO EXTRA-CHARGE

STRUCTURE

- ▶ steel structure, made of cold rolled galvanized special profiles
- ▶ pre-installed with T-guides T 45 x 5 mm and plastic trunking in 2-meter-segments

CABIN

- ▶ „cant-off“-system made of galvanized steel, adjustable guide shoes on both sides
- ▶ compensation device on suspension ropes

HINGED DOORS

- ▶ manual operated hinged doors, made of galvanized steel in accordance to DIN 18090, production controlled by TÜV-authorities
- ▶ side frames made of galvanized steel according to drawing
- ▶ door locks type-tested by TÜV-authorities

DRIVE UNIT

- ▶ drive unit with factory oil filling, standard motor IP54, disc brake and hand wheel, 3 x 400 V / 50 Hz. according to IEC
- ▶ drum Ø 240 mm and pulleys Ø 250 resp. 200 mm for 2 ropes Ø 6 resp. 5 mm suspension 2:1

CONTROLLER

- ▶ call and send control with 24 V, safety circuit 48 V
- ▶ pre-wired with plugs
- ▶ acoustic arrival signal
- ▶ position indicator on each entrance

Note: If travel is more than 4 meters, please contact us if drum will fit in the shaft!

LOADING FRONT AND REAR, MACHINE SIDE ABOVE, WITH SAFETY GEAR

Shaft dimensions are absolute min. plumbed dimensions. The cabin width, depth and height are available in increments of 25 mm. **ATTENTION:** Cabin protection reduces clear entrance openings resp. shaft sizes (please refer to the SKG-OPTIONS)!

The shaft bottom must be carried out according to the construction drawing!

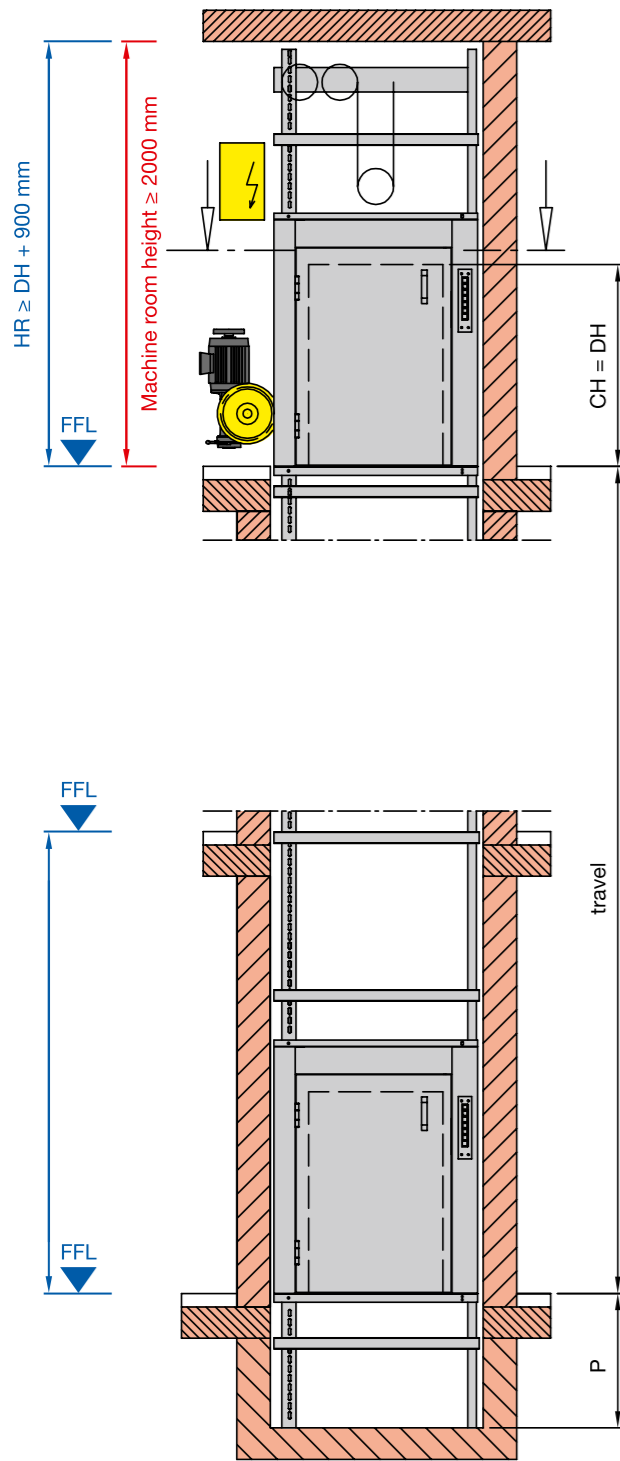

ATTENTION: Machine room door by others!
Please indicate the position of the machine room (left or right) to be advised in relation to the upper landing door!

Machine room width = shaft depth

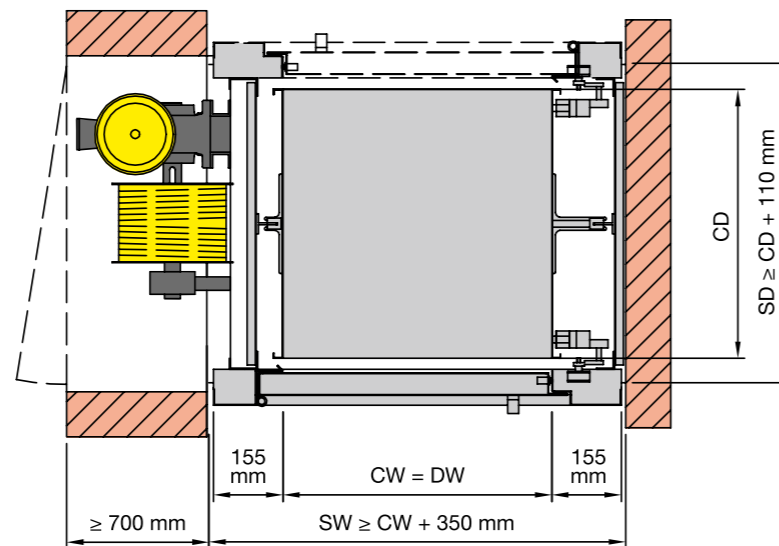

All doors drawn left hinged. Doors right hinged mirror-image.

- CW = cabin width = min. 600 to max. 1000 mm
- CD = cabin depth = min. 700 to max. 1000 mm
- CH = cabin height = min. 800 to max. 1200 mm
- DW = door width = cabin width
- DH = door height = cabin height
- P = pit = min. 250 mm
- SW = shaft width = plumbed min. dimensions
- SD = shaft depth = plumbed min. dimensions
- HR = headroom = clear height of top floor FFL-underside ceiling
- FFL = finished floor level

LOADING FRONT AND REAR, MACHINE SIDE ABOVE, WITH SAFETY GEAR

capacity	cabin floor area	speed	2 stops 2 landings	3 stops 3 landings	4 stops 4 landings	5 stops 5 landings	6 stops 6 landings
100 kg	≤ 1 m ²	0,15 m/s	8.312,- € D.04.100.10.02	9.681,- € D.04.100.10.03	11.076,- € D.04.100.10.04	12.634,- € D.04.100.10.05	14.512,- € D.04.100.10.06
200 kg	≤ 1 m ²	0,15 m/s	9.359,- € D.04.200.10.02	10.728,- € D.04.200.10.03	12.123,- € D.04.200.10.04	13.680,- € D.04.200.10.05	15.559,- € D.04.200.10.06
300 kg	≤ 1 m ²	0,15 m/s	10.540,- € D.04.300.10.02	11.909,- € D.04.300.10.03	13.305,- € D.04.300.10.04	14.862,- € D.04.300.10.05	16.740,- € D.04.300.10.06

from 7 stops and 7 landings prices on request

- ▶ standard complies to EN 81-3 + EU-MRL2006/42/EC
- ▶ 3 meters of travel included for each stop

ATTENTION:
According to EN-81-3 part 8.5 Car entrance, a load protection can be necessary. See extra prices in SKG-OPTIONS on pages 10 and 11.

STANDARD EQUIPMENT AT NO EXTRA-CHARGE

STRUCTURE

- ▶ steel structure, made of cold rolled galvanized special profiles
- ▶ pre-installed with T-guides T 45 x 5 mm and plastic trunking in 2-meter-segments

CABIN

- ▶ „cant-off“-system made of galvanized steel, adjustable guide shoes on both sides
- ▶ compensation device on suspension ropes
- ▶ safety gear, type tested by TÜV-authorities

HINGED DOORS

- ▶ manual operated hinged doors, made of galvanized steel in accordance to DIN 18090, production controlled by TÜV-authorities
- ▶ side frames made of galvanized steel according to drawing
- ▶ door locks type-tested by TÜV-authorities

DRIVE UNIT

- ▶ drive unit with factory oil filling, standard motor IP54, disc brake and hand wheel, 3 x 400 V / 50 Hz. according to IEC
- ▶ drum Ø 240 mm and pulleys Ø 250 resp. 200 mm for 2 ropes Ø 6 resp. 5 mm suspension 2:1

CONTROLLER

- ▶ call and send control with 24 V, safety circuit 48 V
- ▶ pre-wired with plugs
- ▶ acoustic arrival signal
- ▶ position indicator on each entrance

Note: If travel is more than 4 meters, please contact us if drum will fit in the shaft!

LOADING FRONT AND REAR, MACHINE SIDE BELOW, **WITHOUT SAFETY GEAR**

Shaft dimensions are absolute min. plumbed dimensions. The cabin width, depth and height are available in increments of 25 mm. **ATTENTION:** Cabin protection reduces clear entrance openings resp. shaft sizes (please refer to the SKG-OPTIONS)!

Accessible rooms underneath the shaft are not permitted!

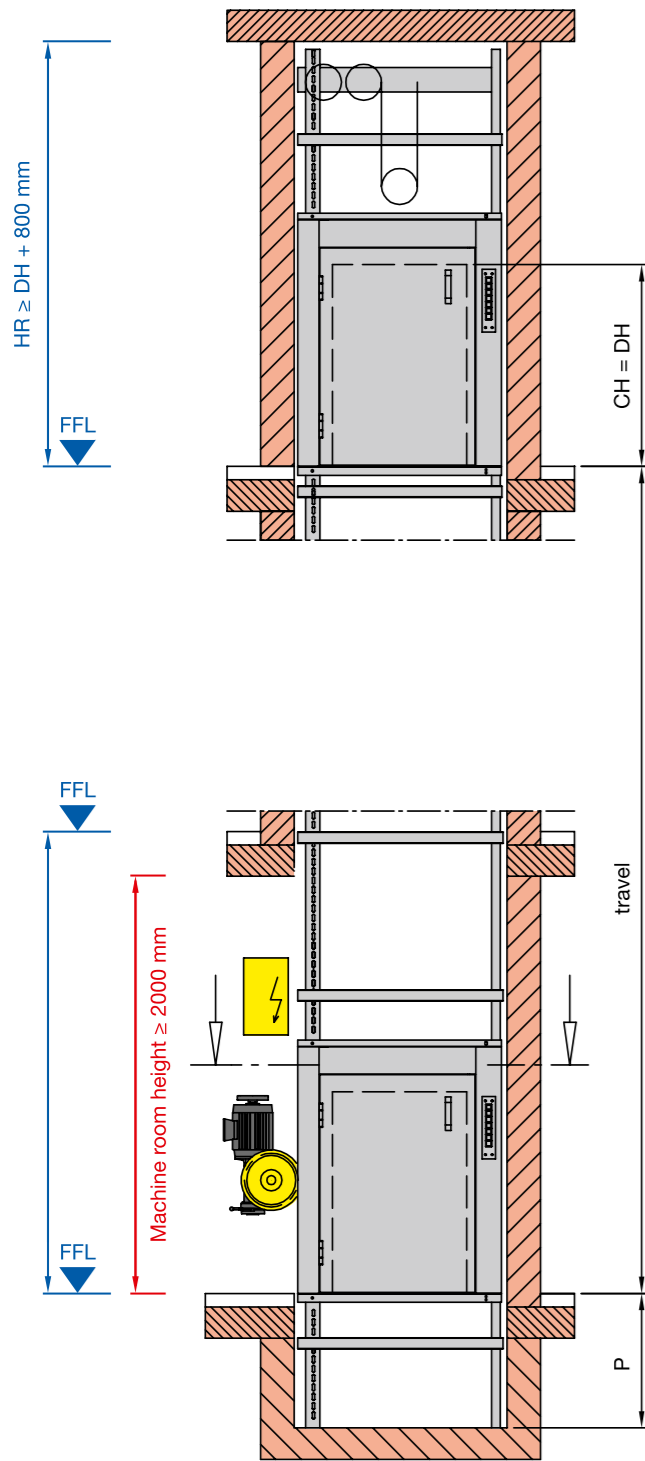

ATTENTION: Machine room door by others!

Please indicate the position of the machine room (left or right) to be advised in relation to the lower landing door!

Machine room width = shaft depth

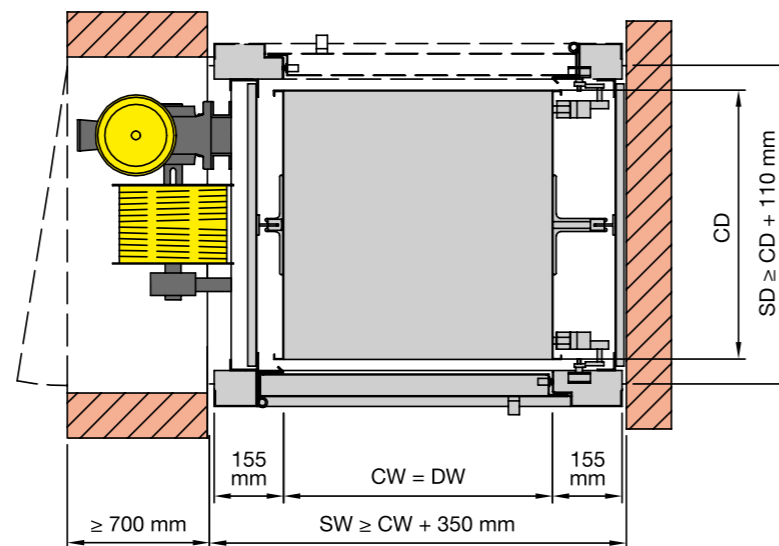

◀ All doors drawn left hinged. Doors right hinged mirror-image. ▶

- CW = cabin width = min. 500 to max. 1000 mm
- CD = cabin depth = min. 650 to max. 1000 mm
- CH = cabin height = min. 800 to max. 1200 mm
- DW = door width = cabin width
- DH = door height = cabin height
- P = pit = min. 250 mm
- SW = shaft width = plumbed min. dimensions
- SD = shaft depth = plumbed min. dimensions
- HR = headroom = clear height of top floor FFL-underside ceiling
- FFL = finished floor level

LOADING FRONT AND REAR, MACHINE SIDE BELOW, **WITHOUT SAFETY GEAR**

capacity	cabin floor area	speed	2 stops 2 landings	3 stops 3 landings	4 stops 4 landings	5 stops 5 landings	6 stops 6 landings
100 kg	≤ 1 m ²	0,15 m/s	7.460,- € D.05.100.10.02	8.829,- € D.05.100.10.03	10.225,- € D.05.100.10.04	11.782,- € D.05.100.10.05	13.661,- € D.05.100.10.06
200 kg	≤ 1 m ²	0,15 m/s	8.507,- € D.05.200.10.02	9.876,- € D.05.200.10.03	11.272,- € D.05.200.10.04	12.829,- € D.05.200.10.05	14.708,- € D.05.200.10.06
300 kg	≤ 1 m ²	0,15 m/s	8.910,- € D.05.300.10.02	10.278,- € D.05.300.10.03	11.675,- € D.05.300.10.04	13.232,- € D.05.300.10.05	15.110,- € D.05.300.10.06

from 7 stops and 7 landings prices on request

- ▶ standard complies to EN 81-3 + EU-MRL2006/42/EC
- ▶ 3 meters of travel included for each stop

ATTENTION:

According to EN-81-3 part 8.5 Car entrance, a load protection can be necessary. See extra prices in SKG-OPTIONS on pages 10 and 11.

STANDARD EQUIPMENT AT NO EXTRA-CHARGE

STRUCTURE

- ▶ steel structure, made of cold rolled galvanized special profiles
- ▶ pre-installed with T-guides T 45 x 5 mm and plastic trunking in 2-meter-segments

CABIN

- ▶ „cant-off“-system made of galvanized steel, adjustable guide shoes on both sides
- ▶ compensation device on suspension ropes

HINGED DOORS

- ▶ manual operated hinged doors, made of galvanized steel in accordance to DIN 18090, production controlled by TÜV-authorities
- ▶ side frames made of galvanized steel according to drawing
- ▶ door locks type-tested by TÜV-authorities

DRIVE UNIT

- ▶ drive unit with factory oil filling, standard motor IP54, disc brake and hand wheel, 3 x 400 V / 50 Hz. according to IEC
- ▶ drum Ø 240 mm and pulleys Ø 250 resp. 200 mm for 2 ropes Ø 6 resp. 5 mm suspension 2:1

CONTROLLER

- ▶ call and send control with 24 V, safety circuit 48 V
- ▶ pre-wired with plugs
- ▶ acoustic arrival signal
- ▶ position indicator on each entrance

Note: If travel is more than 4 meters, please contact us if drum will fit in the shaft!

LOADING FRONT AND REAR, MACHINE SIDE BELOW, WITH SAFETY GEAR

Shaft dimensions are absolute min. plumbed dimensions. The cabin width, depth and height are available in increments of 25 mm. **ATTENTION:** Cabin protection reduces clear entrance openings resp. shaft sizes (please refer to the SKG-OPTIONS)!

The shaft bottom must be carried out according to the construction drawing!

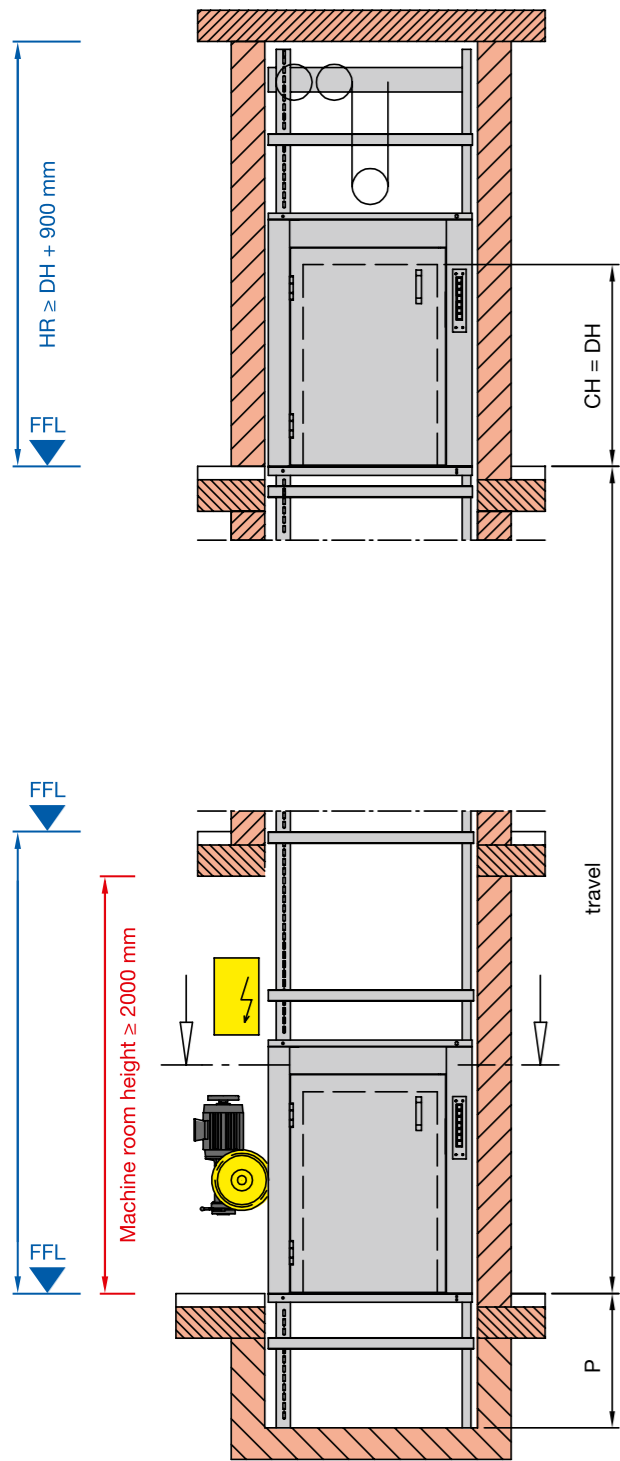

ATTENTION: Machine room door by others!
Please indicate the position of the machine room (left or right) to be advised in relation to the lower landing door!

Machine room width = shaft depth

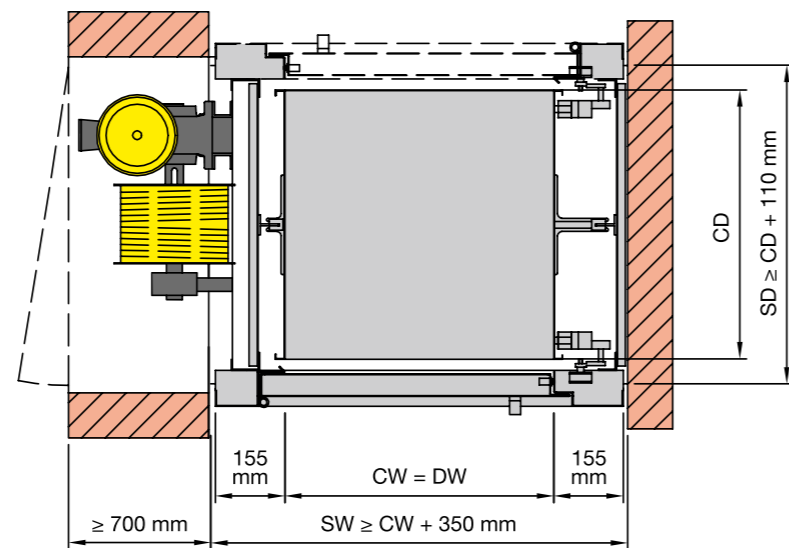

All doors drawn left hinged. Doors right hinged mirror-image.

- CW = cabin width = min. 600 to max. 1000 mm
- CD = cabin depth = min. 700 to max. 1000 mm
- CH = cabin height = min. 800 to max. 1200 mm
- DW = door width = cabin width
- DH = door height = cabin height
- P = pit = min. 250 mm
- SW = shaft width = plumbed min. dimensions
- SD = shaft depth = plumbed min. dimensions
- HR = headroom = clear height of top floor FFL-underside ceiling
- FFL = finished floor level

LOADING FRONT AND REAR, MACHINE SIDE BELOW, WITH SAFETY GEAR

capacity	cabin floor area	speed	2 stops 2 landings	3 stops 3 landings	4 stops 4 landings	5 stops 5 landings	6 stops 6 landings
100 kg	≤ 1 m ²	0,15 m/s	8.312,- € D.06.100.10.02	9.681,- € D.06.100.10.03	11.076,- € D.06.100.10.04	12.634,- € D.06.100.10.05	14.512,- € D.06.100.10.06
200 kg	≤ 1 m ²	0,15 m/s	9.359,- € D.06.200.10.02	10.728,- € D.06.200.10.03	12.123,- € D.06.200.10.04	13.680,- € D.06.200.10.05	15.559,- € D.06.200.10.06
300 kg	≤ 1 m ²	0,15 m/s	10.540,- € D.06.300.10.02	11.909,- € D.06.300.10.03	13.305,- € D.06.300.10.04	14.862,- € D.06.300.10.05	16.740,- € D.06.300.10.06

from 7 stops and 7 landings prices on request

- ▶ standard complies to EN 81-3 + EU-MRL2006/42/EC
- ▶ 3 meters of travel included for each stop

ATTENTION:
According to EN-81-3 part 8.5 Car entrance, a load protection can be necessary. See extra prices in SKG-OPTIONS on pages 10 and 11.

STANDARD EQUIPMENT AT NO EXTRA-CHARGE

STRUCTURE

- ▶ steel structure, made of cold rolled galvanized special profiles
- ▶ pre-installed with T-guides T 45 x 5 mm and plastic trunking in 2-meter-segments

CABIN

- ▶ „cant-off“-system made of galvanized steel, adjustable guide shoes on both sides
- ▶ compensation device on suspension ropes
- ▶ safety gear, type tested by TÜV-authorities

HINGED DOORS

- ▶ manual operated hinged doors, made of galvanized steel in accordance to DIN 18090, production controlled by TÜV-authorities
- ▶ side frames made of galvanized steel according to drawing
- ▶ door locks type-tested by TÜV-authorities

DRIVE UNIT

- ▶ drive unit with factory oil filling, standard motor IP54, disc brake and hand wheel, 3 x 400 V / 50 Hz. according to IEC
- ▶ drum Ø 240 mm and pulleys Ø 250 resp. 200 mm for 2 ropes Ø 6 resp. 5 mm suspension 2:1

CONTROLLER

- ▶ call and send control with 24 V, safety circuit 48 V
- ▶ pre-wired with plugs
- ▶ acoustic arrival signal
- ▶ position indicator on each entrance

Note: If travel is more than 4 meters, please contact us if drum will fit in the shaft!

ADJACENT ENTRANCES, MACHINE ABOVE, **WITHOUT SAFETY GEAR**

Shaft dimensions are absolute min. plumbed dimensions. The cabin width, depth and height are available in increments of 25 mm. **ATTENTION:** Cabin protection reduces clear entrance openings resp. shaft sizes (please refer to the SKG-OPTIONS)!

Accessible rooms underneath the shaft are not permitted!

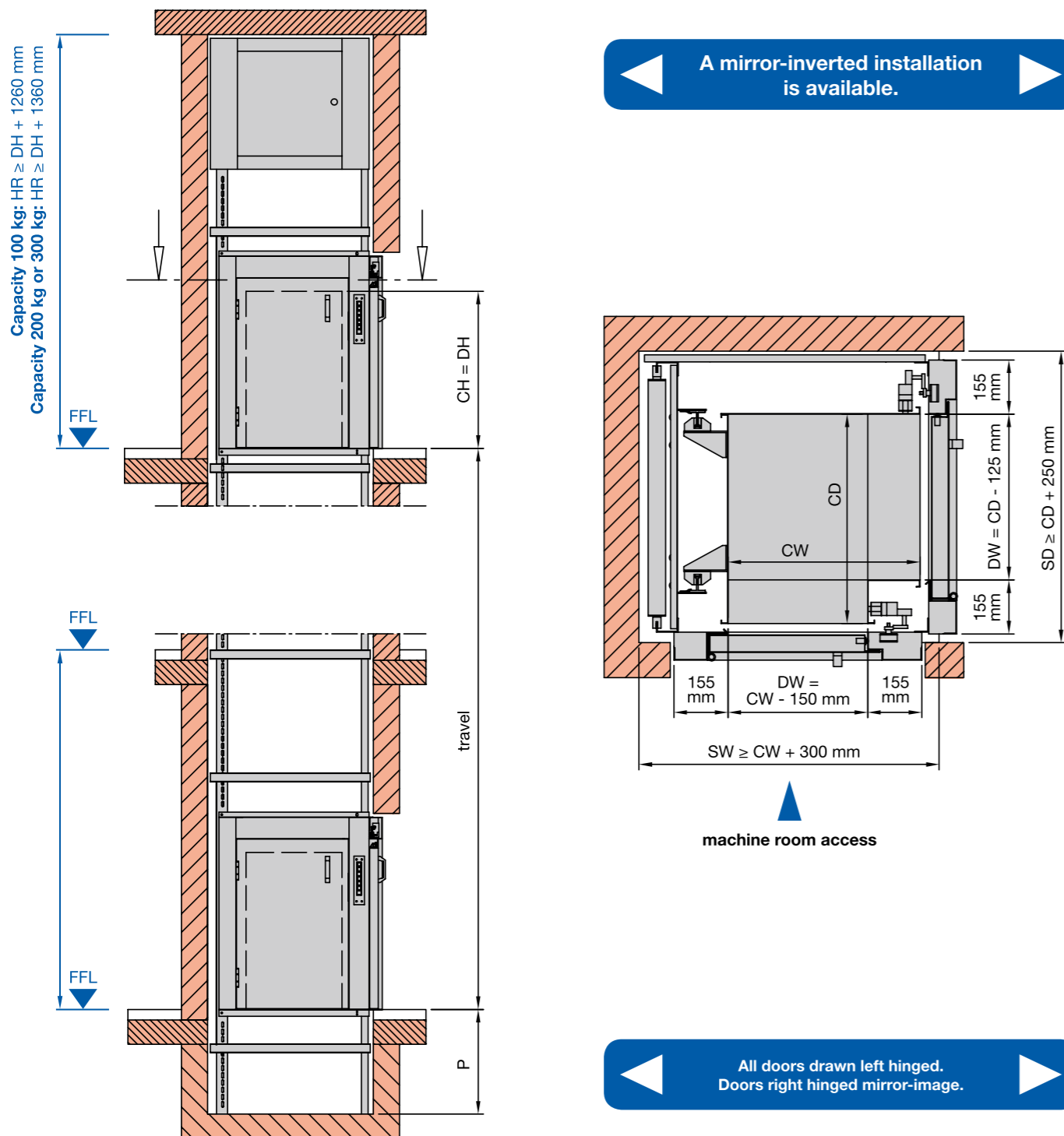

- CW = cabin width = min. 700 to max. 1000 mm
- CD = cabin depth = min. 700 to max. 1000 mm
- CH = cabin height = min. 800 to max. 1200 mm
- DW = door width = cabin width -150 mm, cabin depth -125 mm
- DH = door height = cabin height
- P = pit = min. 250 mm
- SW = shaft width = plumbed min. dimensions
- SD = shaft depth = plumbed min. dimensions
- HR = headroom = clear height of top floor FFL-underside ceiling
- FFL = finished floor level

ADJACENT ENTRANCES, MACHINE ABOVE, **WITHOUT SAFETY GEAR**

capacity	cabin floor area	speed	2 stops 2 landings	3 stops 3 landings	4 stops 4 landings	5 stops 5 landings	6 stops 6 landings
100 kg	≤ 1 m ²	0,27 m/s	7.514,- € D.09.100.10.02	8.883,- € D.09.100.10.03	10.278,- € D.09.100.10.04	11.835,- € D.09.100.10.05	13.715,- € D.09.100.10.06
200 kg	≤ 1 m ²	0,25 m/s	7.782,- € D.09.200.10.02	9.152,- € D.09.200.10.03	10.547,- € D.09.200.10.04	12.104,- € D.09.200.10.05	13.983,- € D.09.200.10.06
300 kg	≤ 1 m ²	0,25 m/s	7.810,- € D.09.300.10.02	9.178,- € D.09.300.10.03	10.574,- € D.09.300.10.04	12.130,- € D.09.300.10.05	14.010,- € D.09.300.10.06

from 7 stops and 7 landings prices on request

- ▶ standard complies to EN 81-3 + EU-MRL2006/42/EC
- ▶ 3 meters of travel included for each stop

ATTENTION:

According to EN-81-3 part 8.5 Car entrance, a load protection can be necessary. See extra prices in SKG-OPTIONS on pages 10 and 11.

STANDARD EQUIPMENT AT NO EXTRA-CHARGE

STRUCTURE

- ▶ steel structure, made of cold rolled galvanized special profiles
- ▶ pre-installed with T-guides T 45 x 5 mm and plastic trunking in 2-meter-segments

CABIN

- ▶ „cant-off“-system made of galvanized steel, adjustable guide shoes on both sides
- ▶ compensation device on suspension ropes / chains

HINGED DOORS

- ▶ manual operated hinged doors, made of galvanized steel in accordance to DIN 18090, production controlled by TÜV-authorities
- ▶ side frames made of galvanized steel according to drawing
- ▶ door locks type-tested by TÜV-authorities

MACHINE ROOM DOOR

- ▶ single hinged door (DW ≥ 800 mm = double hinged), with sash lock, both hinging sides available
- ▶ side frames made of galvanized steel according to drawing

DRIVE UNIT

- ▶ drive unit with factory oil filling, standard motor IP54, disc brake and hand wheel, 3 x 400 V / 50 Hz. according to IEC
- ▶ capacity = 100 kg: sheave Ø 300 diameter for 2 resp. 3 ropes Ø 6 mm
- ▶ capacity = 200 or 300 kg: 2 chain wheels for 2 chains 5/8 x 3/8" DIN 8187

COUNTERWEIGHT OR BALANCE WEIGHT

- ▶ galvanized frame construction with iron infills

CONTROLLER

- ▶ call and send control with 24 V, safety circuit 48 V
- ▶ pre-wired with plugs
- ▶ acoustic arrival signal
- ▶ position indicator on each entrance
- ▶ machine room light with socket

ADJACENT ENTRANCES, MACHINE ABOVE, WITH SAFETY GEAR

Shaft dimensions are absolute min. plumbed dimensions. The cabin width, depth and height are available in increments of 25 mm. **ATTENTION:** Cabin protection reduces clear entrance openings resp. shaft sizes (please refer to the SKG-OPTIONS)!

The shaft bottom must be carried out according to the construction drawing!

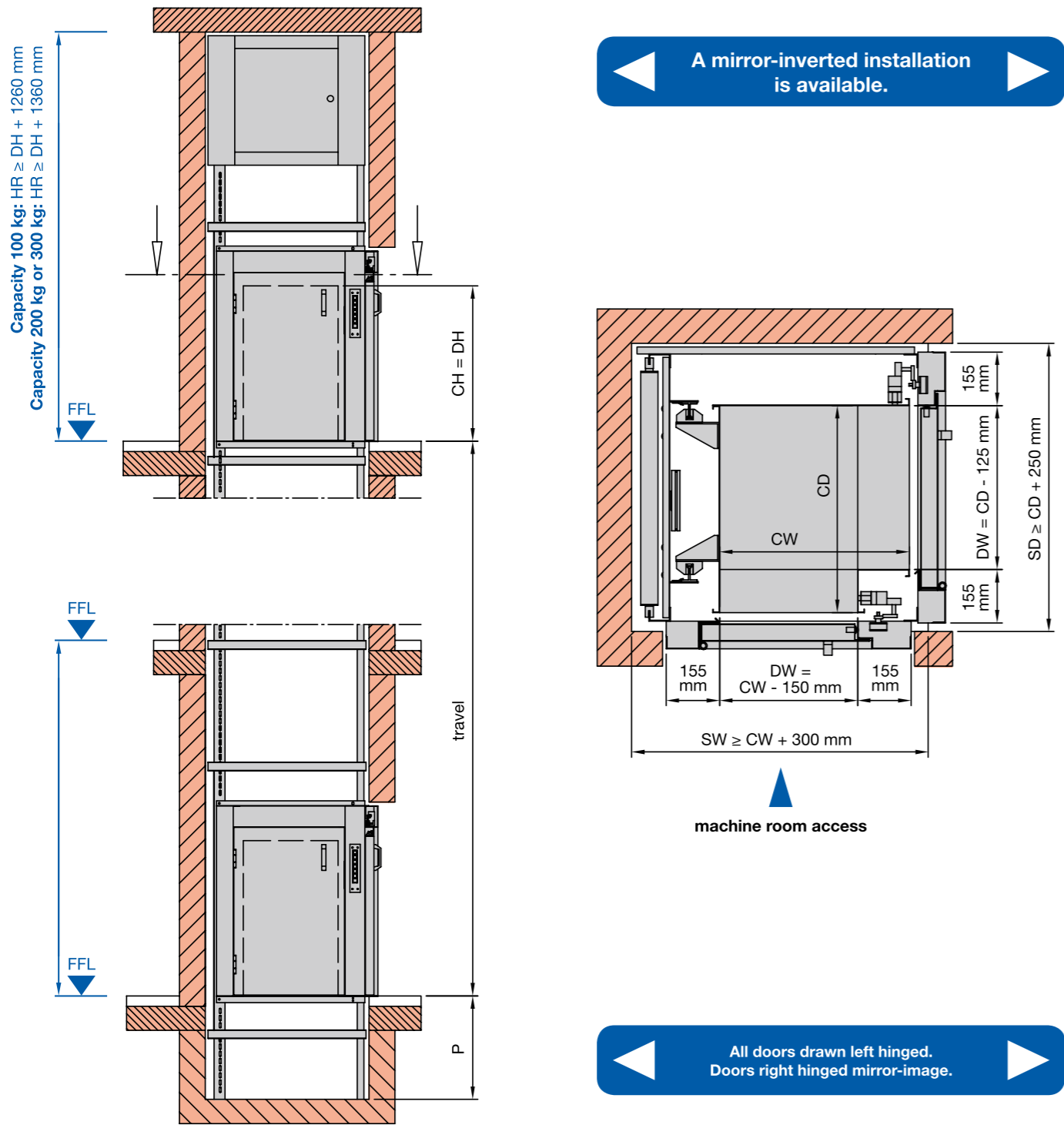

- CW = cabin width = min. 700 to max. 1000 mm
- CD = cabin depth = min. 700 to max. 1000 mm
- CH = cabin height = min. 800 to max. 1200 mm
- DW = door width = cabin width -150 mm, cabin depth -125 mm
- DH = door height = cabin height
- P = pit = min. 250 mm
- SW = shaft width = plumbed min. dimensions
- SD = shaft depth = plumbed min. dimensions
- HR = headroom = clear height of top floor FFL-underside ceiling
- FFL = finished floor level

All doors drawn left hinged. Doors right hinged mirror-image.

ADJACENT ENTRANCES, MACHINE ABOVE, WITH SAFETY GEAR

capacity	cabin floor area	speed	2 stops 2 landings	3 stops 3 landings	4 stops 4 landings	5 stops 5 landings	6 stops 6 landings
100 kg	≤ 1 m ²	0,15 m/s	9.010,- € D.10.100.10.02	10.378,- € D.10.100.10.03	11.775,- € D.10.100.10.04	13.332,- € D.10.100.10.05	15.210,- € D.10.100.10.06
200 kg	≤ 1 m ²	0,15 m/s	10.057,- € D.10.200.10.02	11.425,- € D.10.200.10.03	12.822,- € D.10.200.10.04	14.379,- € D.10.200.10.05	16.257,- € D.10.200.10.06
300 kg	≤ 1 m ²	0,15 m/s	10.218,- € D.10.300.10.02	11.587,- € D.10.300.10.03	12.980,- € D.10.300.10.04	14.539,- € D.10.300.10.05	16.418,- € D.10.300.10.06

from 7 stops and 7 landings prices on request

- ▶ standard complies to EN 81-3 + EU-MRL2006/42/EC
- ▶ 3 meters of travel included for each stop

ATTENTION: According to EN-81-3 part 8.5 Car entrance, a load protection can be necessary. See extra prices in SKG-OPTIONS on pages 10 and 11.

STANDARD EQUIPMENT AT NO EXTRA-CHARGE

STRUCTURE

- ▶ steel structure, made of cold rolled galvanized special profiles
- ▶ pre-installed with T-guides T 45 x 5 mm and plastic trunking in 2-meter-segments
- ▶ buffer Ø 80 mm

CABIN

- ▶ „cant-off“-system made of galvanized steel, adjustable guide shoes on both sides
- ▶ compensation device on suspension ropes / chains
- ▶ safety gear, type tested by TÜV-authorities

HINGED DOORS

- ▶ manual operated hinged doors, made of galvanized steel in accordance to DIN 18090, production controlled by TÜV-authorities
- ▶ side frames made of galvanized steel according to drawing
- ▶ door locks type-tested by TÜV-authorities

MACHINE ROOM DOOR

- ▶ single hinged door (DW ≥ 800 mm = double hinged), with sash lock, both hinging sides available
- ▶ side frames made of galvanized steel according to drawing

DRIVE UNIT

- ▶ drive unit with factory oil filling, standard motor IP54, disc brake and hand wheel, 3 x 400 V / 50 Hz. according to IEC
- ▶ drum Ø 240 mm and pulleys Ø 250 resp. 200 mm for 2 ropes Ø 6 resp. 5 mm suspension 2:1

CONTROLLER

- ▶ call and send control with 24 V, safety circuit 48 V
- ▶ pre-wired with plugs
- ▶ acoustic arrival signal
- ▶ position indicator on each entrance
- ▶ machine room light with socket

Note: If travel is more than 4 meters, please contact us if drum will fit in the shaft!

3-SIDES ADJACENT ENTRANCES, MACHINE ABOVE, WITHOUT SAFETY GEAR

Shaft dimensions are absolute min. plumbed dimensions. The cabin width, depth and height are available in increments of 25 mm. **ATTENTION:** Cabin protection reduces clear entrance openings resp. shaft sizes (please refer to the SKG-OPTIONS)!

Accessible rooms underneath the shaft are not permitted!

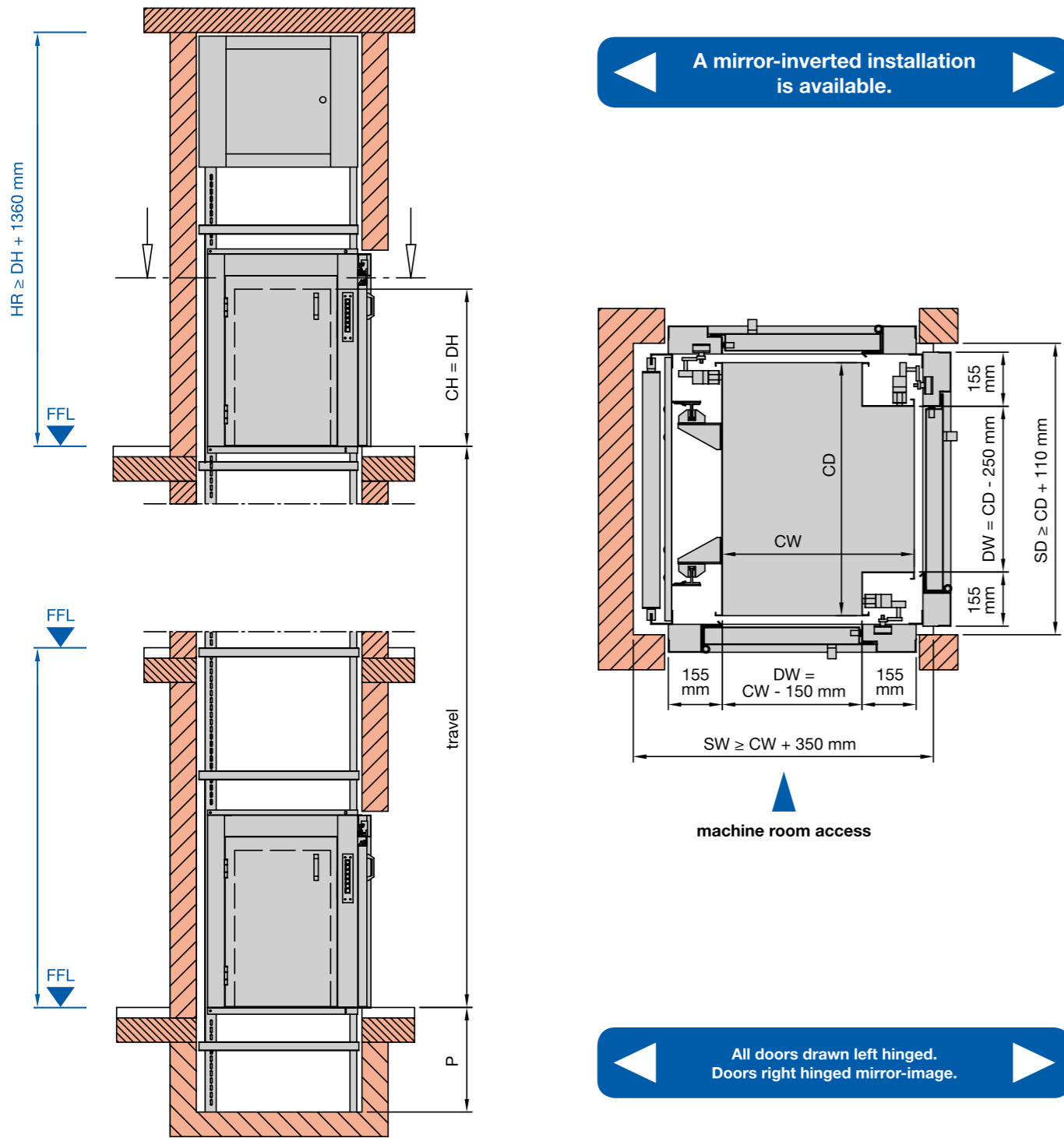

- CW = cabin width min. 700 to max. 1000 mm
- CD = cabin depth min. 700 to max. 1000 mm
- CH = cabin height min. 800 to max. 1200 mm
- DW = door width = cabin width -150 mm, cabin depth -200 mm
- DH = door height = cabin height
- P = pit = min. 250 mm
- SW = shaft width = plumbed min. dimensions
- SD = shaft depth = plumbed min. dimensions
- HR = headroom = clear height of top floor FFL-underside ceiling
- FFL = finished floor level

3-SIDES ADJACENT ENTRANCES, MACHINE ABOVE, WITHOUT SAFETY GEAR

capacity	cabin floor area	speed	2 stops 2 landings	3 stops 3 landings	4 stops 4 landings	5 stops 5 landings	6 stops 6 landings
100 kg	≤ 1 m ²	0,27 m/s	8.158,- € D.17.100.10.02	8.883,- € D.17.100.10.03	10.278,- € D.17.100.10.04	11.835,- € D.17.100.10.05	13.715,- € D.17.100.10.06
200 kg	≤ 1 m ²	0,25 m/s	8.426,- € D.17.200.10.02	9.152,- € D.17.200.10.03	10.547,- € D.17.200.10.04	12.104,- € D.17.200.10.05	13.983,- € D.17.200.10.06
300 kg	≤ 1 m ²	0,25 m/s	8.454,- € D.17.300.10.02	9.178,- € D.17.300.10.03	10.574,- € D.17.300.10.04	12.130,- € D.17.300.10.05	14.010,- € D.17.300.10.06

from 7 stops and 7 landings prices on request

- ▶ standard complies to EN 81-3 + EU-MRL2006/42/EC
- ▶ 3 meters of travel included for each stop

ATTENTION:

According to EN-81-3 part 8.5 Car entrance, a load protection can be necessary. See extra prices in SKG-OPTIONS on pages 10 and 11.

STANDARD EQUIPMENT AT NO EXTRA-CHARGE

STRUCTURE

- ▶ steel structure, made of cold rolled galvanized special profiles
- ▶ pre-installed with T-guides T 45 x 5 mm and plastic trunking in 2-meter-segments

CABIN

- ▶ „cant-off“-system made of galvanized steel, adjustable guide shoes on both sides
- ▶ compensation device on suspension ropes / chains

HINGED DOORS

- ▶ manual operated hinged doors, made of galvanized steel in accordance to DIN 18090, production controlled by TÜV-authorities
- ▶ side frames made of galvanized steel according to drawing
- ▶ door locks type-tested by TÜV-authorities

MACHINE ROOM DOOR

- ▶ single hinged door (DW ≥ 800 mm = double hinged), with sash lock, both hinging sides available
- ▶ side frames made of galvanized steel according to drawing

DRIVE UNIT

- ▶ drive unit with factory oil filling, standard motor IP54, disc brake and hand wheel, 3 x 400 V / 50 Hz. according to IEC
- ▶ capacity = 100 kg: sheave Ø 300 diameter for 2 resp. 3 ropes Ø 6 mm
- ▶ capacity > 100 to 300 kg: 2 chain wheels for 2 chains 5/8 x 3/8" DIN 8187

COUNTERWEIGHT OR BALANCE WEIGHT

- ▶ galvanized frame construction with iron infills

CONTROLLER

- ▶ call and send control with 24 V, safety circuit 48 V
- ▶ pre-wired with plugs
- ▶ acoustic arrival signal
- ▶ position indicator on each entrance
- ▶ machine room light with socket

LOADING FRONT AND REAR, MACHINE SIDE BELOW, **WITHOUT SAFETY GEAR**

Shaft dimensions are absolute min. plumbed dimensions. The cabin width, depth and height are available in increments of 25 mm. **ATTENTION:** Cabin protection reduces clear entrance openings resp. shaft sizes (please refer to the SKG-OPTIONS)!

Accessible rooms underneath the shaft are not permitted!

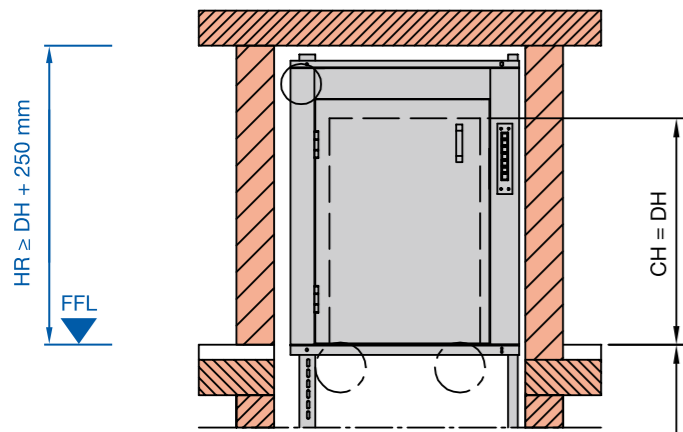

UNDER COUNTERLIFT

ATTENTION: Machine room door by others!

Please indicate the position of the machine room (left or right) to be advised in relation to the lower landing door!

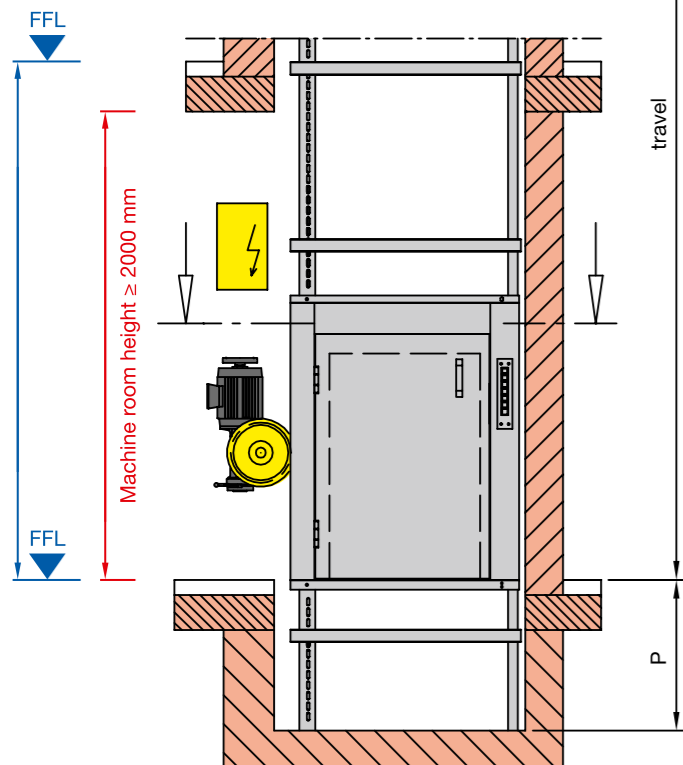

Machine room width = shaft depth

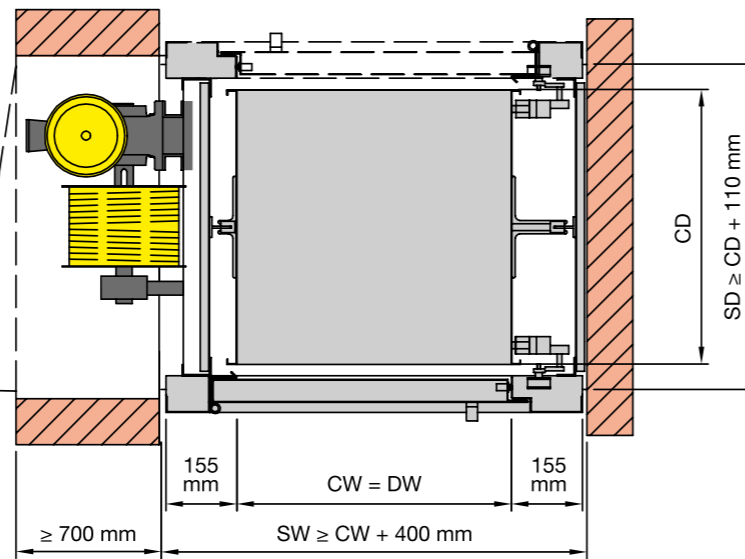

All doors drawn left hinged. Doors right hinged mirror-image.

- CW = cabin width = min. 500 to max. 1000 mm
- CD = cabin depth = min. 650 to max. 1000 mm
- CH = cabin height = min. 800 to max. 1200 mm
- DW = door width = cabin width
- DH = door height = cabin height
- P = pit = min. 600 mm
- SW = shaft width = plumbed min. dimensions
- SD = shaft depth = plumbed min. dimensions
- HR = headroom = clear height of top floor FFL-underside ceiling
- FFL = finished floor level

LOADING FRONT AND REAR, MACHINE SIDE BELOW, **WITHOUT SAFETY GEAR**

capacity	cabin floor area	speed	2 stops 2 landings	3 stops 3 landings	4 stops 4 landings	5 stops 5 landings	6 stops 6 landings
100 kg	≤ 1 m ²	0,15 m/s	7.943,- € D.26.100.10.02	9.312,- € D.26.100.10.03	10.708,- € D.26.100.10.04	12.265,- € D.26.100.10.05	14.144,- € D.26.100.10.06
200 kg	≤ 1 m ²	0,15 m/s	8.990,- € D.26.200.10.02	10.359,- € D.26.200.10.03	11.756,- € D.26.200.10.04	13.312,- € D.26.200.10.05	15.191,- € D.26.200.10.06
300 kg	≤ 1 m ²	0,15 m/s	9.393,- € D.26.300.10.02	10.762,- € D.26.300.10.03	12.158,- € D.26.300.10.04	13.715,- € D.26.300.10.05	15.593,- € D.26.300.10.06

from 7 stops and 7 landings prices on request

- ▶ standard complies to EN 81-3 + EU-MRL2006/42/EC
- ▶ 3 meters of travel included for each stop

ATTENTION:

According to EN-81-3 part 8.5 Car entrance, a load protection can be necessary. See extra prices in SKG-OPTIONS on pages 10 and 11.

STANDARD EQUIPMENT AT NO EXTRA-CHARGE

STRUCTURE

- ▶ steel structure, made of cold rolled galvanized special profiles
- ▶ pre-installed with T-guides T 45 x 5 mm and plastic trunking in 2-meter-segments

CABIN

- ▶ „cant-off“-system made of galvanized steel, adjustable guide shoes on both sides
- ▶ compensation device on suspension ropes

HINGED DOORS

- ▶ manual operated hinged doors, made of galvanized steel in accordance to DIN 18090, production controlled by TÜV-authorities
- ▶ side frames made of galvanized steel according to drawing
- ▶ door locks type-tested by TÜV-authorities

DRIVE UNIT

- ▶ drive unit with factory oil filling, standard motor IP54, disc brake and hand wheel, 3 x 400 V / 50 Hz. according to IEC
- ▶ drum Ø 240 mm and pulleys Ø 200 mm for 2 ropes Ø 5 mm suspension 2:1

CONTROLLER

- ▶ call and send control with 24 V, safety circuit 48 V
- ▶ pre-wired with plugs
- ▶ acoustic arrival signal
- ▶ position indicator on each entrance
- ▶ machine room light with socket

LOADING FRONT AND REAR, MACHINE SIDE BELOW, **WITHOUT SAFETY GEAR**

Shaft and pit dimensions are min. plumbed dimensions. There are 2 possible dimensions of the cabin width and cabin depth which are 800 x 800 mm or 1000 x 1000 mm. **ATTENTION:** Cabin protection reduces clear entrance openings resp. shaft sizes (please refer to the SKG-OPTIONS)!

Accessible rooms underneath the shaft are not permitted!

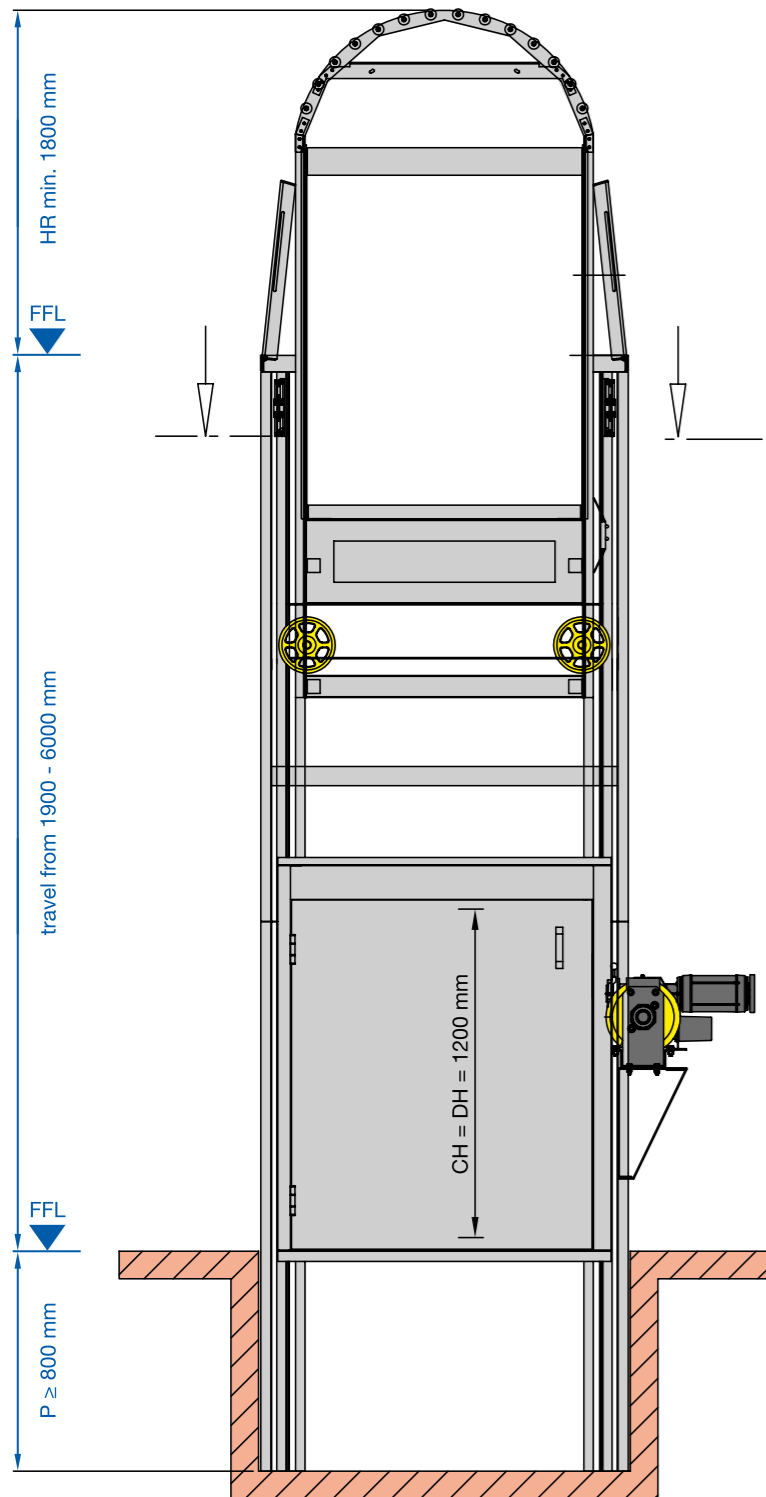
**ATTENTION: Machine room door by others!**

Please indicate the position of the machine room (left or right) to be advised in relation to the upper landing door!

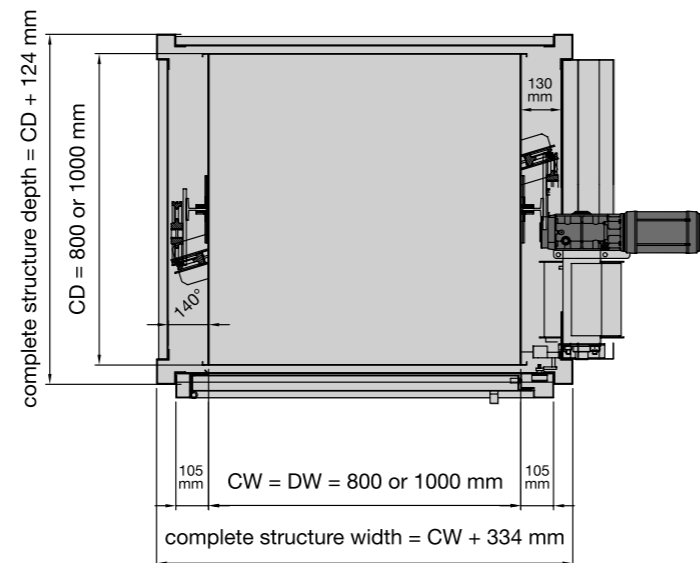
**Possible cabin dimensions:**

Version A = 800 x 800 x 1200 mm

Version B = 1000 x 1000 x 1200 mm

All doors drawn left hinged.
Doors right hinged mirror-image.

For installation in an existing shaft:

min. shaft width = complete structure width + 40 mm
min. shaft depth = complete structure depth + 40 mm

CW	=	cabin width	800 or 1000 mm
CD	=	cabin depth	800 or 1000 mm
CH	=	cabin height	1200 mm
DW	=	door width	= cabin width
DH	=	door height	= cabin height
P	=	pit	= min. 800 mm
SW	=	shaft width	= plumbed min. dimensions
SD	=	shaft depth	= plumbed min. dimensions
HR	=	Headroom	= min. 1800 mm

LOADING FRONT AND REAR, MACHINE SIDE BELOW, **WITHOUT SAFETY GEAR**

capacity	cabin floor area	speed	2 stops 2 landings
300 kg	$\leq 1 \text{ m}^2$	0,15 m/s	11.470,- € U.05.300.10.02

- ▶ standard complies to EN 81-3 + EU-MRL2006/42/EC
- ▶ 3 meters of travel included for each stop

ATTENTION:

According to EN-81-3 part 8.5 Car entrance, a load protection can be necessary. See extra prices in SKG-OPTIONS on pages 10 and 11.

STANDARD EQUIPMENT AT NO EXTRA-CHARGE**STRUCTURE**

- ▶ steel structure, made of cold rolled galvanized special profiles
- ▶ pre-installed with T-guides T 70 x 65 x 9 and plastic trunking in 2-meter-segments
- ▶ compensation device on suspension ropes
- ▶ complete absorption of the flaps' encumbrances
- ▶ prepared for cladding on site

CABIN

- ▶ „cant-off“-system made of galvanized steel, adjustable guide shoes on both sides
- ▶ hushed mechanism for flap opening

HINGED DOOR

- ▶ manual operated hinged door, made of galvanized steel in accordance to DIN 18090, production controlled by TÜV-authorities
- ▶ side frames made of galvanized steel according to drawing
- ▶ door locks type-tested by TÜV-authorities

Flap

- ▶ loading capacity 500 kg / m²
- ▶ automatic opening and closing
- ▶ made as screed tub for any kinds of flooring
- ▶ width of flap = structure width and flap depth = structure depth

DRIVE UNIT

- ▶ drive unit with factory oil filling, standard motor IP54, disc brake and hand wheel, 3 x 400 V / 50 Hz. according to IEC
- ▶ drum Ø 240 mm and pulleys Ø 200 mm for 2 ropes Ø 5 mm suspension 2:1

CONTROLLER

- ▶ „push-to-run“-control with key switch mounted in controller box
- ▶ position indicator on each entrance
- ▶ thermic motor protection as main switch pre-wired on control panel

SKG

SERVICE LIFTS

CABIN WITH 2 SEPARATE COMPARTMENTS ▶▶



ISO-Z

LOADING FRONT AND REAR, MACHINE ABOVE, **WITHOUT SAFETY GEAR**

Shaft and pit dimensions are min. plumbed dimensions. The cabin width, depth and height are available in increments of 25 mm. **ATTENTION:** Cabin protection reduces clear entrance openings resp. shaft sizes (please refer to the SKG-OPTIONS)!

Accessible rooms underneath the shaft are not permitted!

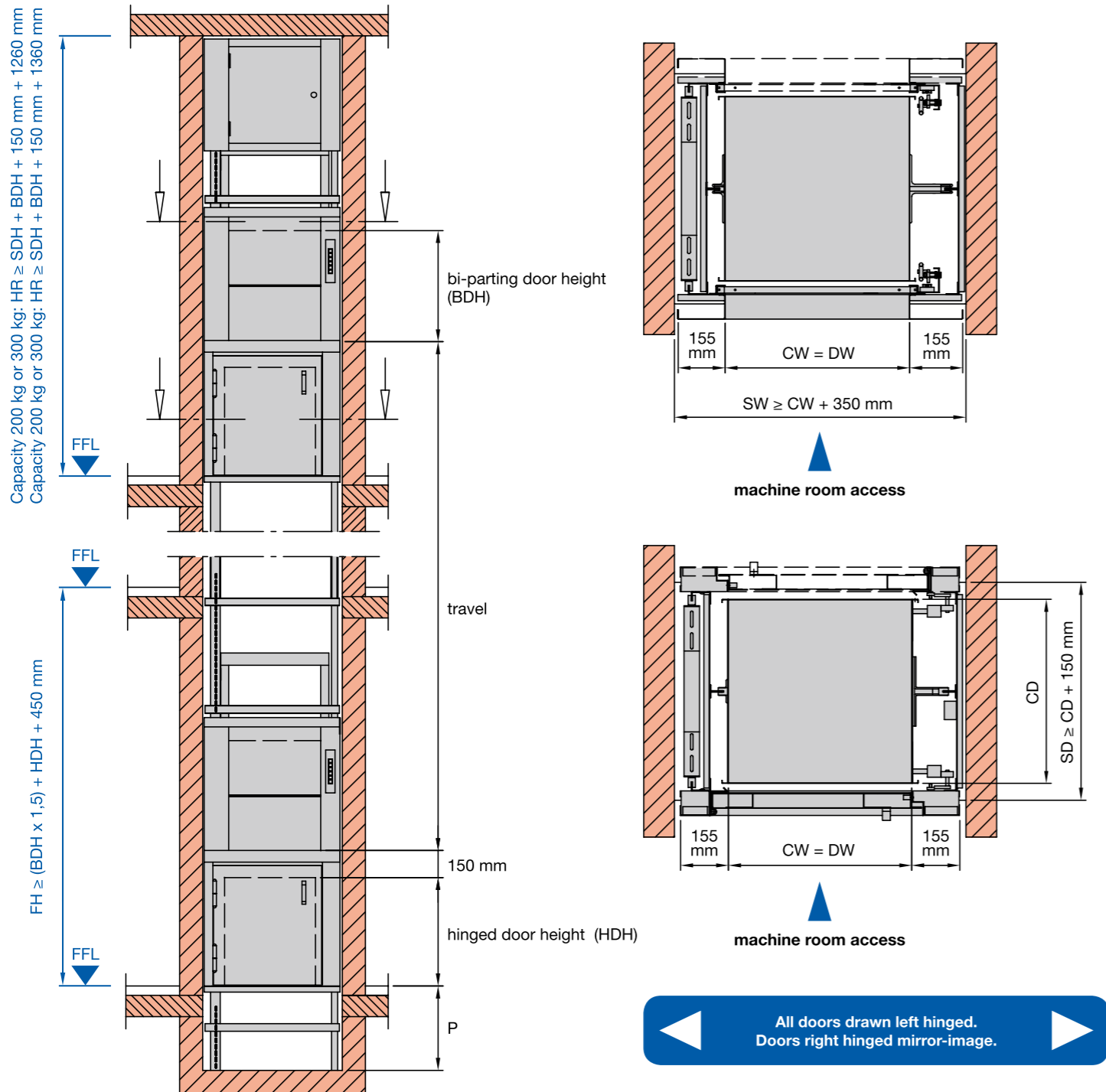

CW	= cabin width	min. 500 to max. 1000 mm
CD	= cabin depth	min. 600 to max. 1000 mm
CH	= cabin height	1750 mm (other heights on demand)
DW	= door width	= cabin width
HDH	= Height of hinged door	= 800 mm (other heights on demand)
BDH	= Height of bi-parting door	= 800 mm (other heights on demand)
P	= pit	= min. 250 mm
SW	= shaft width	= plumbed min. dimensions
SD	= shaft depth	= plumbed min. dimensions
HR	= headroom	= clear height of top floor FFL-underside ceiling
FFL	= finished floor level	
FH	= floor to floor height on landing doors in line	

All doors drawn left hinged.
Doors right hinged mirror-image.

LOADING FRONT AND REAR, MACHINE ABOVE, **WITHOUT SAFETY GEAR**

capacity	cabin floor area	speed	2 stops 2 landings	3 stops 3 landings	4 stops 4 landings	5 stops 5 landings	6 stops 6 landings
100 kg	≤ 1 m ²	0,27 m/s	7.406,- € Z.01.100.10.02	8.776,- € Z.01.100.10.03	10.171,- € Z.01.100.10.04	11.728,- € Z.01.100.10.05	13.607,- € Z.01.100.10.06
200 kg	≤ 1 m ²	0,27 m/s	7.836,- € Z.01.200.10.02	9.259,- € Z.01.200.10.03	10.654,- € Z.01.200.10.04	12.211,- € Z.01.200.10.05	14.091,- € Z.01.200.10.06
300 kg	≤ 1 m ²	0,25 m/s	7.970,- € Z.01.300.10.02	9.393,- € Z.01.300.10.03	10.789,- € Z.01.300.10.04	12.346,- € Z.01.300.10.05	14.224,- € Z.01.300.10.06

from 7 stops and 7 landings prices on request

- ▶ standard complies to EN 81-3 + EU-MRL2006/42/EC
- ▶ 3 meters of travel included for each stop

ATTENTION:

According to EN-81-3 part 8.5 Car entrance, a load protection can be necessary. See extra prices in SKG-OPTIONS on pages 10 and 11.

STANDARD EQUIPMENT AT NO EXTRA-CHARGE

STRUCTURE

- ▶ steel structure, made of cold rolled galvanized special profiles
- ▶ pre-installed with T-guides T 45 x 5 mm and plastic trunking in 2-meter-segments

CABIN

- ▶ „cant-off“-system made of galvanized steel, adjustable guide shoes on both sides
- ▶ compensation device on suspension ropes / chains

Bi-parting / hinged doors

- ▶ manual operated bi-parting doors made of galvanized steel in accordance to DIN 18092,
- ▶ manual operated single hinged doors made of galvanized steel in accordance to DIN 18090, production controlled by TÜV-authorities
- ▶ side frames made of galvanized steel according to drawing
- ▶ door locks type-tested by TÜV-authorities

MACHINE ROOM DOOR

- ▶ single hinged door (DW ≥ 800 mm = double hinged), with sash lock, both hinging sides available
- ▶ side frames made of galvanized steel according to drawing

DRIVE UNIT

- ▶ drive unit with standard motor IP 54 disc brake and handwheel, 3 x 400 V / 50 Hz. according to IEC
- ▶ 2 chain wheels for 2 chains 5/8 x 3/8" DIN 8187

Counterweight

- ▶ galvanized frame construction with iron infills

CONTROLLER

- ▶ call and send control with 24 V, safety circuit 48 V
- ▶ pre-wired with plugs
- ▶ acoustic arrival signal
- ▶ position indicator on each entrance
- ▶ machine room light with socket

LOADING FRONT AND REAR, MACHINE ABOVE, WITH SAFETY GEAR

Shaft and pit dimensions are min. plumbed dimensions. The cabin width, depth and height are available in increments of 25 mm. **ATTENTION:** Cabin protection reduces clear entrance openings resp. shaft sizes (please refer to the SKG-OPTIONS)!

Accessible rooms underneath the shaft are not permitted!

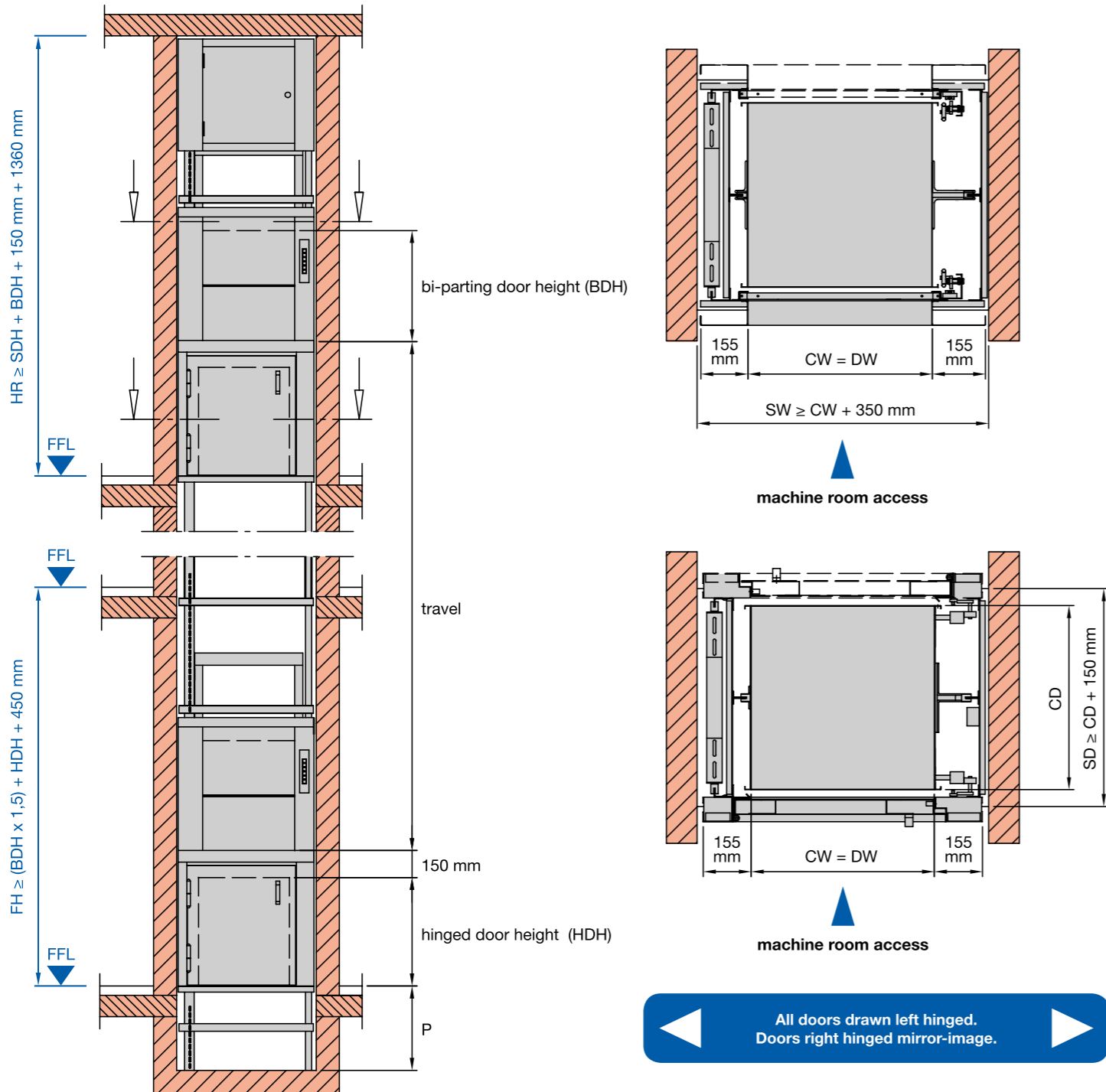

CW	= cabin width	min. 600 to max. 1000 mm
CD	= cabin depth	min. 700 to max. 1000 mm
CH	= cabin height	1750 mm (other heights on demand)
DW	= door width	= cabin width
HDH	= Height of hinged door	= 800 mm (other heights on demand)
BDH	= Height of bi-parting door	= 800 mm (other heights on demand)
P	= pit	= min. 250 mm
SW	= shaft width	= plumbed min. dimensions
SD	= shaft depth	= plumbed min. dimensions
HR	= headroom	= clear height of top floor FFL-underside ceiling
FFL	= finished floor level	
FH	= floor to floor height on landing doors in line	

All doors drawn left hinged. Doors right hinged mirror-image.

LOADING FRONT AND REAR, MACHINE ABOVE, WITH SAFETY GEAR

capacity	cabin floor area	speed	2 stops 2 landings	3 stops 3 landings	4 stops 4 landings	5 stops 5 landings	6 stops 6 landings
100 kg	≤ 1 m ²	0,15 m/s	10.862,- € Z.02.100.10.02	12.230,- € Z.02.100.10.03	13.627,- € Z.02.100.10.04	15.184,- € Z.02.100.10.05	17.063,- € Z.02.100.10.06
200 kg	≤ 1 m ²	0,15 m/s	11.721,- € Z.02.200.10.02	13.089,- € Z.02.200.10.03	14.486,- € Z.02.200.10.04	16.043,- € Z.02.200.10.05	17.921,- € Z.02.200.10.06
300 kg	≤ 1 m ²	0,15 m/s	11.963,- € Z.02.300.10.02	13.332,- € Z.02.300.10.03	14.727,- € Z.02.300.10.04	16.284,- € Z.02.300.10.05	18.163,- € Z.02.300.10.06

from 7 stops and 7 landings prices on request

- ▶ standard complies to EN 81-3 + EU-MRL2006/42/EC
- ▶ 3 meters of travel included for each stop

ATTENTION:

According to EN-81-3 part 8.5 Car entrance, a load protection can be necessary. See extra prices in SKG-OPTIONS on pages 10 and 11.

STANDARD EQUIPMENT AT NO EXTRA-CHARGE

STRUCTURE

- ▶ steel structure, made of cold rolled galvanized special profiles
- ▶ pre-installed with T-guides T 45 x 5 mm and plastic trunking in 2-meter-segments
- ▶ buffer Ø 80 mm

CABIN

- ▶ „cant-off“-system made of galvanized steel, adjustable guide shoes on both sides
- ▶ compensation device on suspension ropes / chains
- ▶ safety gear, type tested by TÜV-authorities

BI-PARTING DOORS / HINGED DOORS

- ▶ manual operated bi-parting doors made of galvanized steel in accordance to DIN 18092, manual operated hinged doors, made of galvanized steel in accordance to DIN 18090, production controlled by TÜV-authorities
- ▶ side frames made of galvanized steel according to drawing
- ▶ door locks type-tested by TÜV-authorities

MACHINE ROOM DOOR

- ▶ single hinged door (DW ≥ 800 mm = double hinged), with sash lock, both hinging sides available
- ▶ side frames made of galvanized steel according to drawing

DRIVE UNIT

- ▶ drive unit with standard motor IP 54 disc brake and handwheel, 3 x 400 V / 50 Hz.
- ▶ according to IEC
- ▶ drum 240 diameter for 2 ropes 5 or 6 mm, suspension 2:1

CONTROLLER

- ▶ call and send control with 24 V, safety circuit 48 V
- ▶ pre-wired with plugs
- ▶ acoustic arrival signal
- ▶ position indicator on each entrance
- ▶ machine room light with socket

Note: If travel is more than 4 meters, please contact us if drum will fit in the shaft!

SKG

GOODS LIFT
WITHOUT PASSENGER TRANSPORT ▶▶



ISO-L
ISO-MAX 300
ISO-MAX 500
ISO-MAX 750
ISO-MAX 1000
ISO-MAX FLEX

LOADING FRONT AND REAR, MACHINE ABOVE, WITH SAFETY GEAR

Shaft and pit dimensions are min. plumbed dimensions. The cabin width, depth and height are available in increments of 25 mm. **ATTENTION:** Cabin protection reduces clear entrance openings resp. shaft sizes (please refer to the SKG-OPTIONS)!

The shaft bottom must be carried out according to the construction drawing!

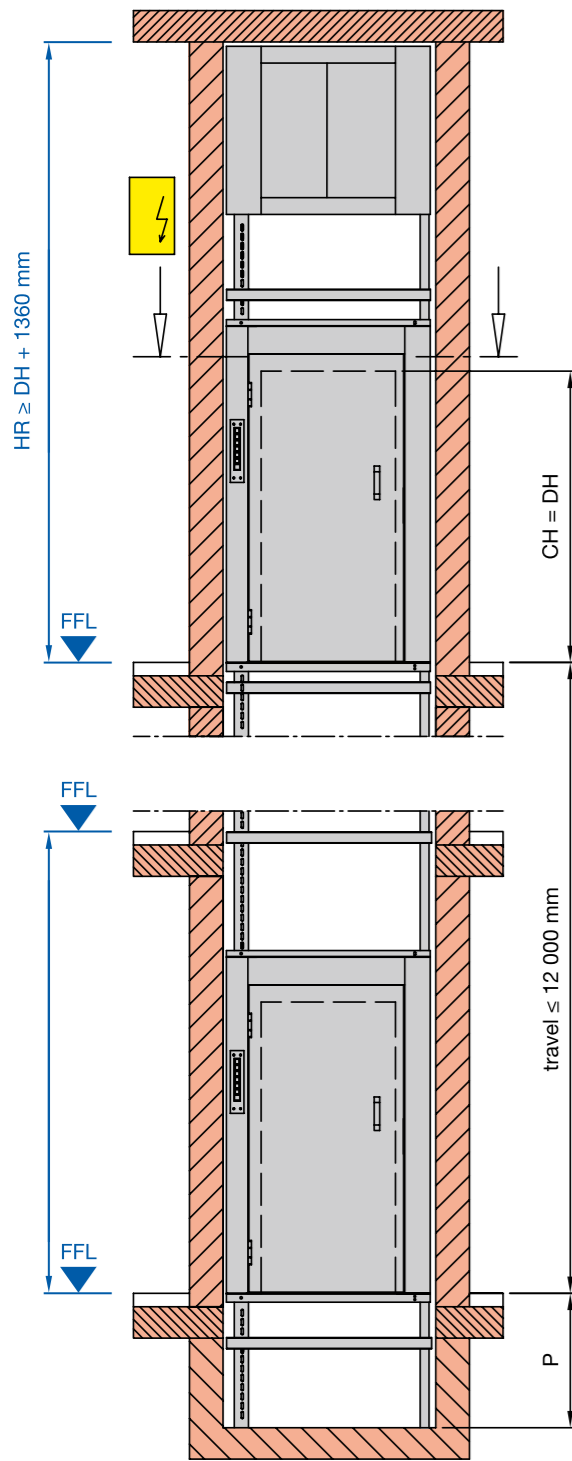

- ▶ Cabin width and depth max 1m
- ▶ cabin surface ≤ 1 m²
- ▶ installation in shaft necessary

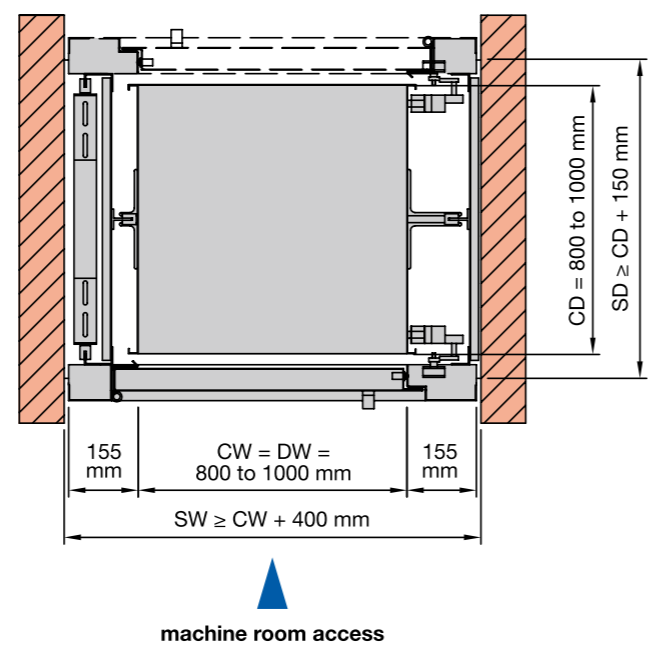

◀ All doors drawn left hinged. Doors right hinged mirror-image. ▶

- CW = cabin width = min. 800 to max. 1000 mm
- CD = cabin depth = min. 800 to max. 1000 mm
- CH = cabin height = min. 1200 to max. 2000 mm
- DW = door width = cabin width
- DH = door height = cabin height
- P = pit = min. 250 mm
- SW = shaft width = plumbed min. dimensions
- SD = shaft depth = plumbed min. dimensions
- HR = headroom = clear height of top floor FFL-underside ceiling
- FFL = finished floor level

LOADING FRONT AND REAR, MACHINE ABOVE, WITH SAFETY GEAR

capacity	cabin floor area	speed	2 stops 2 landings	3 stops 3 landings	4 stops 4 landings	5 stops 5 landings
300 kg	≤ 1 m ²	0,15 m/s	15.479,- € L.29.300.10.02	16.848,- € L.29.300.10.03	18.217,- € L.29.300.10.04	19.586,- € L.29.300.10.05
500 kg	≤ 1 m ²	0,15 m/s	20.391,- € L.29.500.10.02	21.760,- € L.29.500.10.03	23.129,- € L.29.500.10.04	24.498,- € L.29.500.10.05

- ▶ standard complies to EU-MRL 2006/42/EC
- ▶ 3 meters of travel included for each stop

STANDARD EQUIPMENT AT NO EXTRA-CHARGE

STRUCTURE

- ▶ steel structure, made of cold rolled galvanized special profiles
- ▶ pre-installed with I-guides T 45 x 5 mm and plastic trunking in 2-meter-segments
- ▶ baffle plates

CABIN

- ▶ „cant-off“-system made of galvanized steel, adjustable guide shoes on both sides
- ▶ compensation device on suspension ropes / chains
- ▶ safety gear

HINGED DOORS

- ▶ manual operated hinged doors, made of galvanized steel in accordance to DIN 18090, production controlled by TÜV-authorities
- ▶ side frames made of galvanized steel according to drawing
- ▶ door locks type-tested by TÜV-authorities

MACHINE ROOM DOOR

- ▶ double hinged door with sash lock
- ▶ side frames made of galvanized steel according to drawing

DRIVE UNIT

- ▶ drive unit with factory oil filling, standard motor IP54, disc brake and hand wheel, 3 x 400 V / 50 Hz. according to IEC
- ▶ drum Ø 240 mm and pulleys Ø 250 resp. 200 mm for 2 ropes Ø 6 resp. 5 mm suspension 2:1

CONTROLLER

- ▶ call and send control with 24 V, safety circuit 48 V
- ▶ pre-wired with plugs
- ▶ adjustable and time-limited despatch delay device (1-5 s)
- ▶ acoustic arrival signal
- ▶ position indicator on each entrance
- ▶ thermic motor protection as main switch pre-wired on control panel
- ▶ machine room light with socket

LOADING FRONT AND REAR, MACHINE ABOVE, WITH SAFETY GEAR

Shaft and pit dimensions are min. plumbed dimensions. The cabin width, depth and height are available in increments of 25 mm. **ATTENTION:** Cabin protection reduces clear entrance openings resp. shaft sizes (please refer to the SKG-OPTIONS)!

The shaft bottom must be carried out according to the construction drawing!

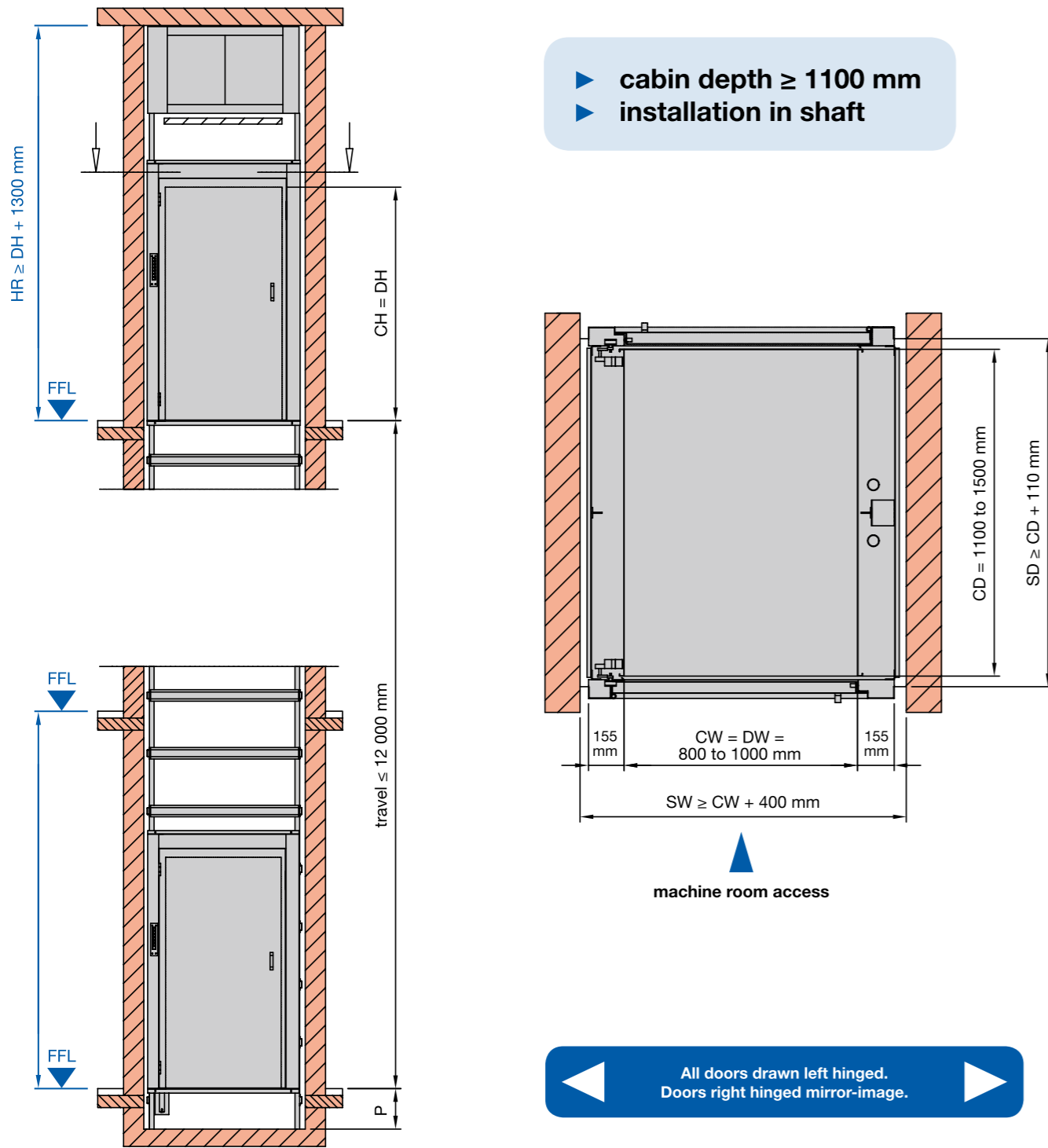

- CW = cabin width = min. 800 to max. 1000 mm
- CD = cabin depth = min. 1100 to max. 1500 mm
- CH = cabin height = min. 1200 to max. 2000 mm
- DW = door width = cabin width
- DH = door height = cabin height
- P = pit = min. 200 mm
- SW = shaft width = plumbed min. dimensions
- SD = shaft depth = plumbed min. dimensions
- HR = headroom = clear height of top floor FFL-underside ceiling
- FFL = finished floor level

LOADING FRONT AND REAR, MACHINE ABOVE, WITH SAFETY GEAR

capacity	cabin floor area	speed	cabin height	2 stops 2 landings	3 stops 3 landings	4 stops 4 landings	5 stops 5 landings
300 kg	up to 1,5 m ²	0,1 m/s	1,2 m	12.500,- € L.30.300.14.02	14.003,- € L.30.300.14.03	15.533,- € L.30.300.14.04	17.250,- € L.30.300.14.05
500 kg	up to 1,5 m ²	0,1 m/s	1,2 m	14.834,- € L30.500.14.02	16.338,- € L30.500.14.03	17.868,- € L30.500.14.04	19.590,- € L30.500.14.05
300 kg	up to 1,5 m ²	0,1 m/s	>1,2 m	17.975,- € L.31.300.14.02	19.479,- € L.31.300.14.03	21.008,- € L.31.300.14.04	22.726,- € L.31.300.14.05
500 kg	up to 1,5 m ²	0,1 m/s	>1,2 m	20.069,- € L.31.500.14.02	21.572,- € L.31.500.14.03	23.102,- € L.31.500.14.04	24.820,- € L.31.500.14.05

- ▶ complies to machine directive 2006/42/EC
- ▶ 3 meters of travel included for each stop

STANDARD EQUIPMENT AT NO EXTRA-CHARGE

STRUCTURE

- ▶ steel structure, made of cold rolled galvanized special profiles
- ▶ pre-installed with I-guides T 45 x 5 mm and plastic trunking in 2-meter-segments
- ▶ baffle plates
- ▶ buffer Ø 80 mm

CABIN

- ▶ „cant-off“-system made of galvanized steel, adjustable guide shoes on both sides
- ▶ compensation device on suspension ropes / chains
- ▶ type tested safety gear
- ▶ bumper rails

HINGED DOORS

- ▶ manual operated hinged doors, made of galvanized steel in accordance to DIN 18090, production controlled by TÜV-authorities
- ▶ side frames made of galvanized steel according to drawing
- ▶ door locks type-tested by TÜV-authorities

MACHINE ROOM DOOR

- ▶ double hinged door with sash lock
- ▶ side frames made of galvanized steel according to drawing

DRIVE UNIT

- ▶ drive unit with factory oil filling, standard motor IP54, disc brake and hand wheel, 3 x 400 V / 50 Hz.
- ▶ 2 chain wheels for chains 5/8" x 3/8"

CONTROLLER

- ▶ call and send control with 24 V, safety circuit 48 V
- ▶ pre-wired with plugs
- ▶ adjustable and time-limited despatch delay device (1-5 s)
- ▶ electronic overload contact
- ▶ acoustic arrival signal
- ▶ position indicator on each entrance
- ▶ thermic motor protection as main switch pre-wired on control panel
- ▶ machine room light with socket

LOADING FRONT AND REAR, MACHINE ABOVE, **WITH SAFETY GEAR**

Shaft and pit dimensions are min. plumbed dimensions. The cabin width, depth and height are available in increments of 25 mm. **ATTENTION:** Cabin protection reduces clear entrance openings resp. shaft sizes (please refer to the SKG-OPTIONS)!

The shaft bottom must be carried out according to the construction drawing!

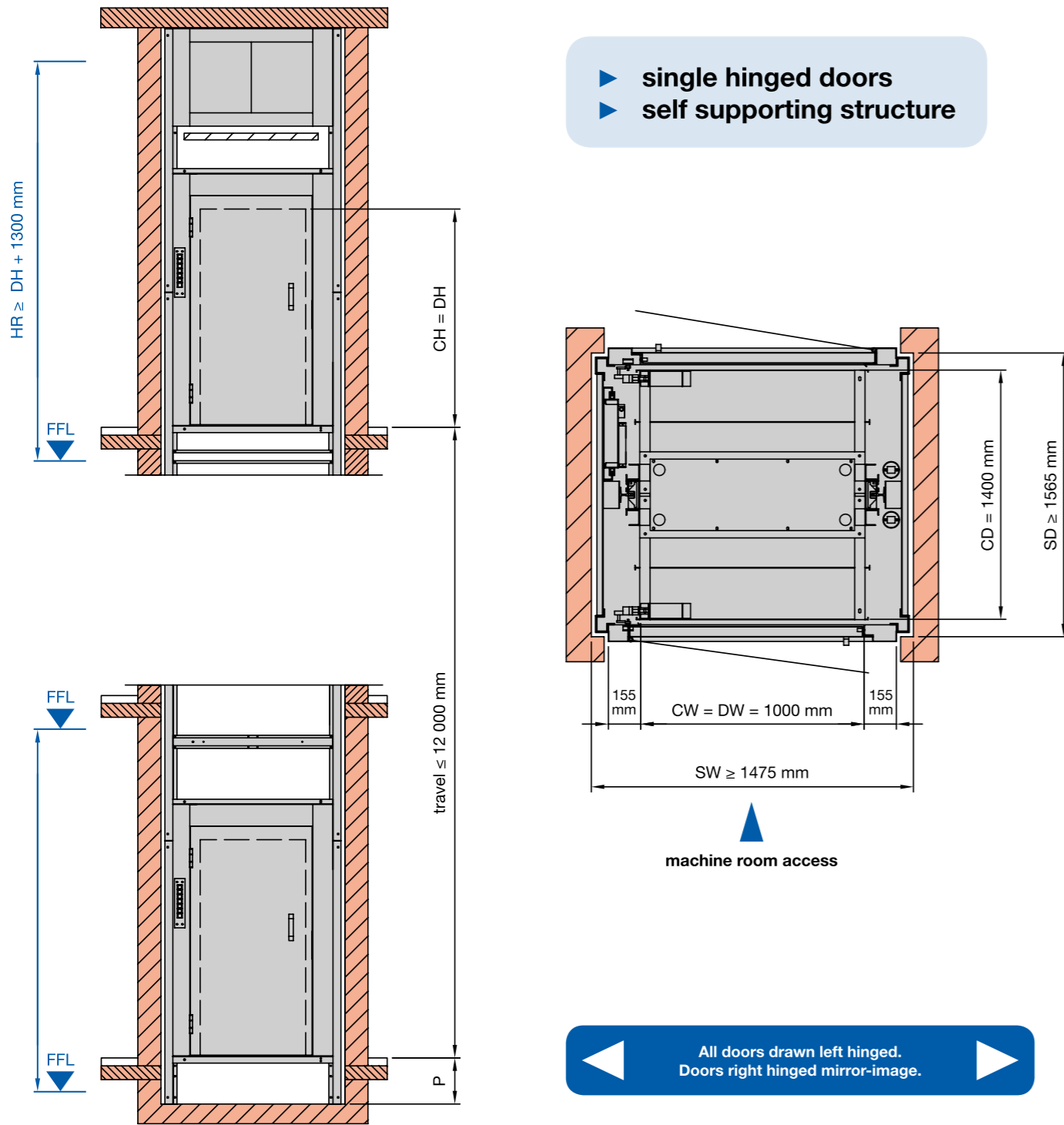

CW	=	cabin width	1000 mm
CD	=	cabin depth	1400 mm
CH	=	cabin height	min. 1200 to max. 2000 mm
DW	=	door width	= cabin width
DH	=	door height	= cabin height
P	=	pit	= min. 200 mm
SW	=	shaft width	= plumbed min. dimensions
SD	=	shaft depth	= plumbed min. dimensions
HR	=	headroom	= clear height of top floor FFL-underside ceiling
FFL	=	finished floor level	

LOADING FRONT AND REAR, MACHINE ABOVE, **WITH SAFETY GEAR**

capacity	cabin floor area	speed	cabin height	2 stops 2 landings	3 stops 3 landings	4 stops 4 landings	5 stops 5 landings
750 kg	1,4 m ²	0,1 m/s	1,2 m	15.960,- € L.32.750.14.02	17.430,- € L.32.750.14.03	18.953,- € L.32.750.14.04	20.633,- € L.32.750.14.05
1000 kg	1,4 m ²	0,1 m/s	1,2 m	17.588,- € L.32.1000.14.02	19.058,- € L.32.1000.14.03	20.580,- € L.32.1000.14.04	22.260,- € L.32.1000.14.05
750 kg	1,4 m ²	0,1 m/s	>1,2 m	21.683,- € L.33.750.14.02	23.163,- € L.33.750.14.03	24.675,- € L.33.750.14.03	26.355,- € L.33.750.14.05
1000 kg	1,4 m ²	0,1 m/s	>1,2 m	22.418,- € L.33.1000.14.02	23.888,- € L.33.1000.14.03	25.410,- € L.33.1000.14.04	27.090,- € L.33.1000.14.05

- ▶ complies to machine directive 2006/42/EC
- ▶ 3 meters of travel included for each stop

STANDARD EQUIPMENT AT NO EXTRA-CHARGE

STRUCTURE

- ▶ steel structure, made of cold rolled galvanized special profiles
- ▶ pre-installed with I-guides T 70 x 65 x 9 mm
- ▶ baffle plates
- ▶ buffer Ø 80 mm

CABIN

- ▶ „cant-off“-system made of galvanized steel, adjustable guide shoes on both sides
- ▶ compensation device on suspension ropes
- ▶ type tested safety gear
- ▶ bumper rails

HINGED DOORS

- ▶ manual operated hinged doors, made of galvanized steel in accordance to DIN 18090, production controlled by TÜV-authorities
- ▶ side frames made of galvanized steel according to drawing
- ▶ door locks type-tested by TÜV-authorities

MACHINE ROOM DOOR

- ▶ double hinged door with sash lock
- ▶ side frames made of galvanized steel according to drawing

DRIVE UNIT

- ▶ drive unit with factory oil filling, standard motor IP54, disc brake and hand wheel, 3 x 400 V / 50 Hz.
- ▶ 2 chain wheels for chains 5/8" x 3/8" suspension 2:1

CONTROLLER

- ▶ call and send control with 24 V, safety circuit 48 V
- ▶ pre-wired with plugs
- ▶ adjustable and time-limited despatch delay device (1-5 s)
- ▶ acoustic arrival signal
- ▶ electronic overload contact
- ▶ position indicator on each entrance
- ▶ thermic motor protection as main switch pre-wired on control panel
- ▶ machine room light with socket

LOADING FRONT AND REAR, MACHINE ABOVE, WITH SAFETY GEAR

Shaft and pit dimensions are min. plumbed dimensions. The cabin width, depth and height are available in increments of 25 mm. **ATTENTION:** Cabin protection reduces clear entrance openings resp. shaft sizes (please refer to the SKG-OPTIONS)!

The shaft bottom must be carried out according to the construction drawing!

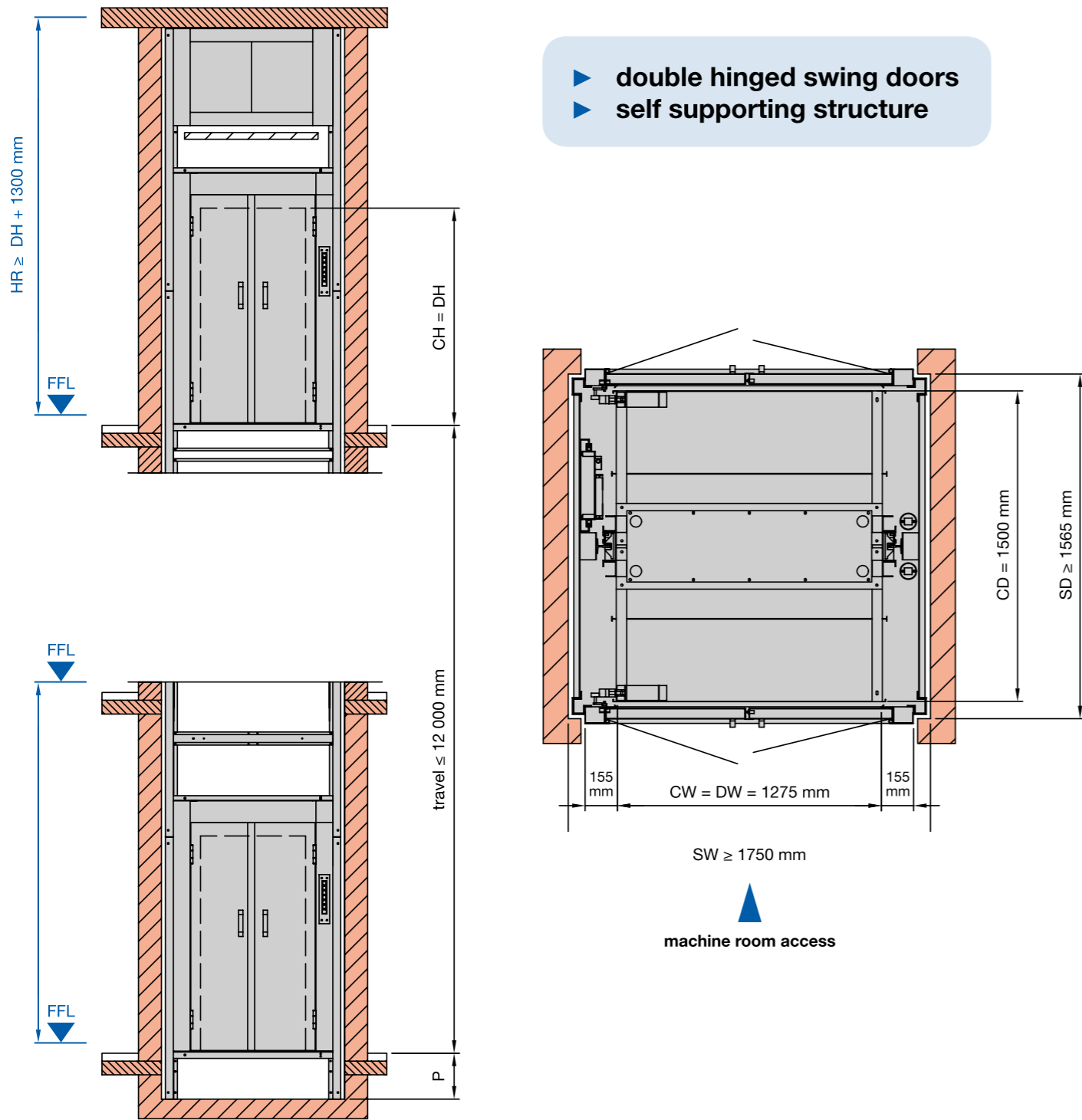

CW	=	cabin width	1275 mm
CD	=	cabin depth	1500 mm
CH	=	cabin height	min. 1200 to max. 2000 mm
DW	=	door width	= cabin width
DH	=	door height	= cabin height
P	=	pit	= min. 200 mm
SW	=	shaft width	= plumbed min. dimensions
SD	=	shaft depth	= plumbed min. dimensions
HR	=	headroom	= clear height of top floor FFL-underside ceiling
FFL	=	finished floor level	

LOADING FRONT AND REAR, MACHINE ABOVE, WITH SAFETY GEAR

capacity	cabin floor area	speed	cabin height	2 stops 2 landings	3 stops 3 landings	4 stops 4 landings	5 stops 5 landings
750 kg	1,9 m ²	0,1 m/s	1,2 m	18.113,- € L.32.750.20.02	19.583,- € L.32.750.20.03	21.263,- € L.32.750.20.04	22.943,- € L.32.750.20.05
1000 kg	1,9 m ²	0,1 m/s	1,2 m	19.740,- € L.32.1000.20.02	21.210,- € L.32.1000.20.03	22.733,- € L.32.1000.20.04	24.413,- € L.32.1000.20.05
750 kg	1,9 m ²	0,1 m/s	>1,2 m	23.835,- € L.33.750.20.02	25.305,- € L.33.750.20.03	26.828,- € L.33.750.20.03	28.508,- € L.33.750.20.05
1000 kg	1,9 m ²	0,1 m/s	>1,2 m	25.305,- € L.33.1000.20.02	26.775,- € L.33.1000.20.03	28.403,- € L.33.1000.20.04	29.978,- € L.33.1000.20.05

- ▶ complies to machine directive 2006/42/EC
- ▶ 3 meters of travel included for each stop

STANDARD EQUIPMENT AT NO EXTRA-CHARGE

STRUCTURE

- ▶ steel structure, made of cold rolled galvanized special profiles
- ▶ pre-installed with I-guides T 70 x 65 x 9 mm
- ▶ baffle plates
- ▶ buffer Ø 80 mm

CABIN

- ▶ „cant-off“-system made of galvanized steel, adjustable guide shoes on both sides
- ▶ compensation device on suspension ropes
- ▶ type tested safety gear
- ▶ bumper rails

HINGED DOORS

- ▶ manual operated double hinged doors, made of galvanized steel in accordance to DIN 18090, production controlled by TÜV-authorities
- ▶ side frames made of galvanized steel according to drawing
- ▶ door locks type-tested by TÜV-authorities

MACHINE ROOM DOOR

- ▶ double hinged door with sash lock
- ▶ side frames made of galvanized steel according to drawing

DRIVE UNIT

- ▶ drive unit with factory oil filling, standard motor IP54, disc brake and hand wheel, 3 x 400 V / 50 Hz.
- ▶ 2 chain wheels for chains 5/8" x 3/8" suspension 2:1

CONTROLLER

- ▶ call and send control with 24 V, safety circuit 48 V
- ▶ pre-wired with plugs
- ▶ adjustable and time-limited despatch delay device (1-5 s)
- ▶ acoustic arrival signal
- ▶ electronic overload contact
- ▶ position indicator on each entrance
- ▶ thermic motor protection as main switch pre-wired on control panel
- ▶ machine room light with socket

LOADING FRONT AND REAR, MACHINE ABOVE, WITH SAFETY GEAR

Shaft and pit dimensions are min. plumbed dimensions. The cabin width, depth and height are available in increments of 25 mm. **ATTENTION:** Cabin protection reduces clear entrance openings resp. shaft sizes (please refer to the SKG-OPTIONS)!

The shaft bottom must be carried out according to the construction drawing!

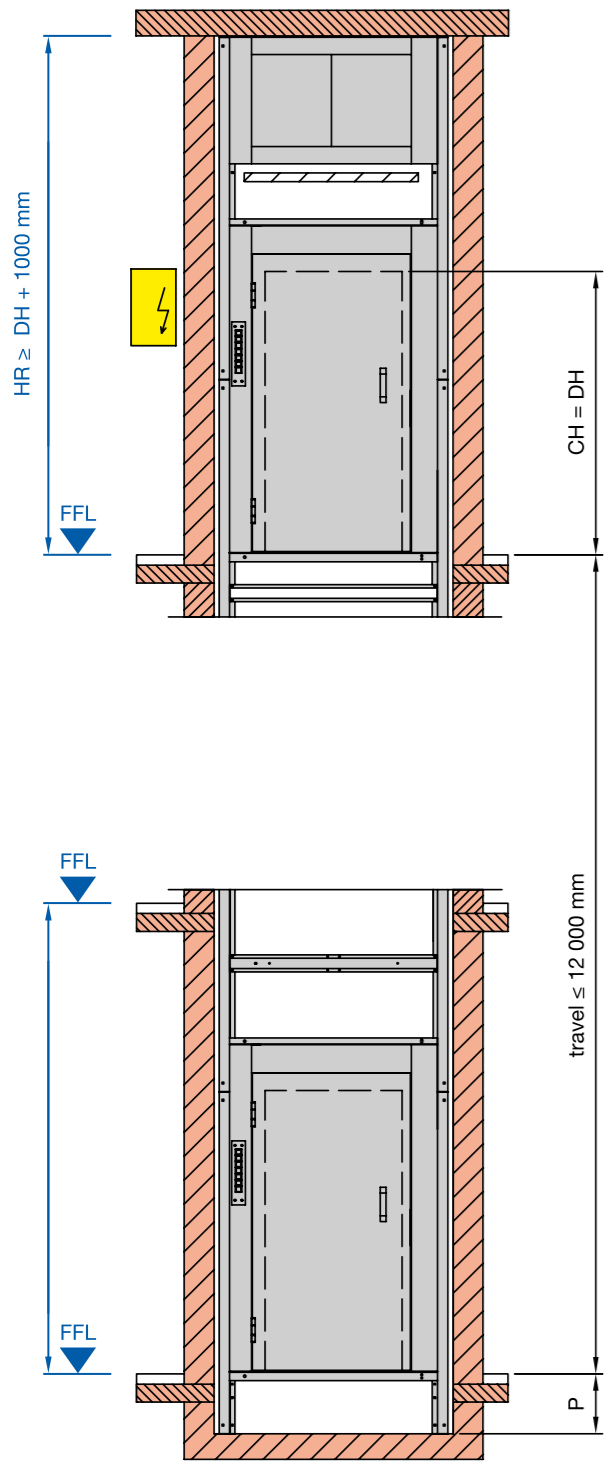

- ▶ capacity 750 or 1000 kg
- ▶ cabin height 1200 to 2000 mm
- ▶ single hinged swing doors
- ▶ self supporting structure

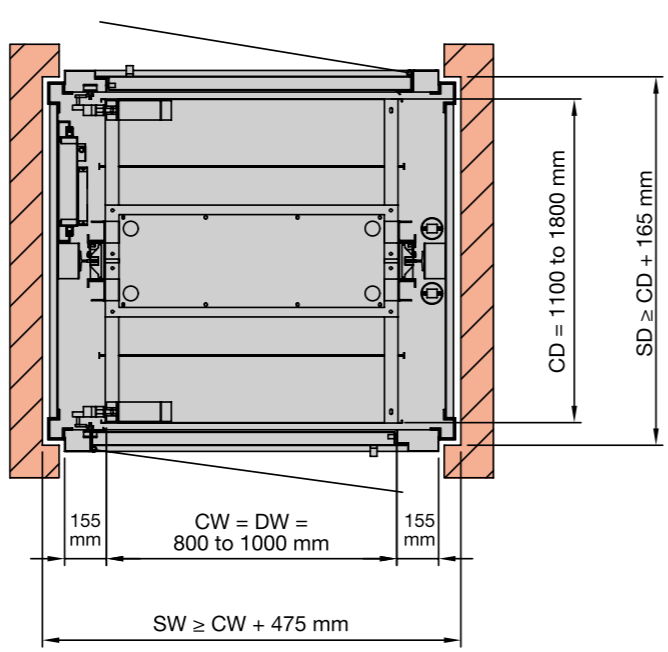

machine room access

All doors drawn left hinged.
Doors right hinged mirror-image.

CW	=	cabin width	min. 800 to max. 1000 mm
CD	=	cabin depth	min. 1100 to max. 1800 mm
CH	=	cabin height	min. 1200 to max. 2000 mm
DW	=	door width	= cabin width
DH	=	door height	= cabin height
P	=	pit	min. 200 mm
SW	=	shaft width	= plumbed min. dimensions
SD	=	shaft depth	= plumbed min. dimensions
HR	=	headroom	= clear height of top floor FFL-underside ceiling
FFL	=	finished floor level	

LOADING FRONT AND REAR, MACHINE ABOVE, WITH SAFETY GEAR

capacity	cabin floor area	speed	cabin height	2 stops 2 landings	3 stops 3 landings	4 stops 4 landings	5 stops 5 landings
750 kg	up to 2 m ²	0,1 m/s	1,2 to 2 m	25.440,- € L.34.750.20.02	28.540,- € L.34.750.20.03	31.640,- € L.34.750.20.04	34.740,- € L.34.750.20.05
1000 kg	up to 2 m ²	0,1 m/s	1,2 to 2 m	26.950,- € L34.1000.20.02	30.050,- € L34.1000.20.03	33.150,- € L34.1000.20.04	36.250,- € L34.1000.20.05

- ▶ complies to machine directive 2006/42/EC and EN81-31
- ▶ 3 meters of travel included for each stop

STANDARD EQUIPMENT AT NO EXTRA-CHARGE

STRUCTURE

- ▶ steel structure, made of cold rolled galvanized special profiles
- ▶ pre-installed with I-guides T 70 x 65 x 9 mm
- ▶ baffle plates
- ▶ buffer Ø 80 mm

CABIN

- ▶ „cant-off“-system made of galvanized steel, adjustable guide shoes on both sides
- ▶ compensation device on suspension ropes
- ▶ type tested safety gear
- ▶ bumper rails

HINGED DOORS

- ▶ manual operated double hinged doors, made of galvanized steel in accordance to DIN 18090, production controlled by TÜV-authorities
- ▶ side frames made of galvanized steel according to drawing
- ▶ door locks type-tested by TÜV-authorities

MAINTENANCE DOOR

- ▶ double hinged door with sash lock
- ▶ side frames made of galvanized steel according to drawing

DRIVE UNIT

- ▶ drive unit with factory oil filling, standard motor IP54, disc brake and hand wheel, 3 x 400 V / 50 Hz.
- ▶ 2 chain wheels for chains 5/8" x 3/8" suspension 2:1

CONTROLLER

- ▶ call and send control with 24 V, safety circuit 48 V
- ▶ pre-wired with plugs
- ▶ adjustable and time-limited despatch delay device (1-5 s)
- ▶ acoustic arrival signal
- ▶ electronic overload contact
- ▶ position indicator on each entrance
- ▶ thermic motor protection as main switch pre-wired on control panel
- ▶ machine room light with socket
- ▶ return control in headroom

LOADING FRONT AND REAR, MACHINE ABOVE, **WITH SAFETY GEAR**

Shaft and pit dimensions are min. plumbed dimensions. The cabin width, depth and height are available in increments of 25 mm. **ATTENTION:** Cabin protection reduces clear entrance openings resp. shaft sizes (please refer to the SKG-OPTIONS)!

The shaft bottom must be carried out according to the construction drawing!

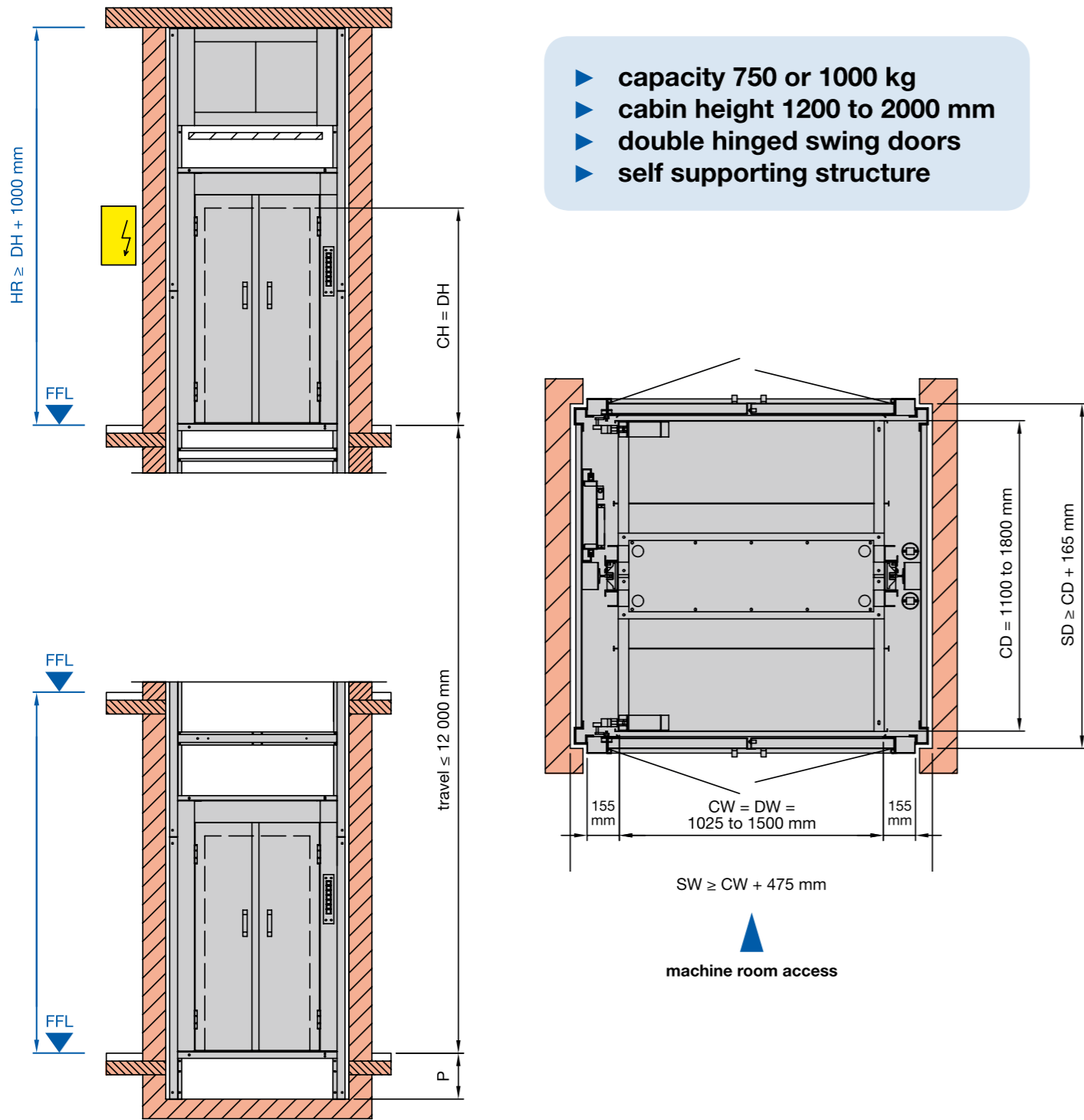

CW	=	cabin width	min. 1025 to max. 1500 mm
CD	=	cabin depth	min. 1100 to max. 1800 mm
CH	=	cabin height	min. 1200 to max. 2000 mm
DW	=	door width	= cabin width
DH	=	door height	= cabin height
P	=	pit	= min. 200 mm
SW	=	shaft width	= plumbed min. dimensions
SD	=	shaft depth	= plumbed min. dimensions
HR	=	headroom	= clear height of top floor FFL-underside ceiling
FFL	=	finished floor level	

LOADING FRONT AND REAR, MACHINE ABOVE, **WITH SAFETY GEAR**

capacity	cabin floor area	speed	cabin height	2 stops 2 landings	3 stops 3 landings	4 stops 4 landings	5 stops 5 landings
750 kg	up to 3 m ²	0,1 m/s	1,2 to 2 m	27.200,- € L.35.750.30.02	30.700,- € L.35.750.30.03	34.200,- € L.35.750.30.04	37.700,- € L.35.750.30.05
1000 kg	up to 3 m ²	0,1 m/s	1,2 to 2 m	28.300,- € L.35.1000.30.02	31.800,- € L.35.1000.30.03	35.300,- € L.35.1000.30.04	38.800,- € L.35.1000.30.05

- ▶ complies to machine directive 2006/42/EC and EN81-31
- ▶ 3 meters of travel included for each stop

STANDARD EQUIPMENT AT NO EXTRA-CHARGE

STRUCTURE

- ▶ steel structure, made of cold rolled galvanized special profiles
- ▶ pre-installed with I-guides T 70 x 65 x 9 mm
- ▶ baffle plates
- ▶ buffer Ø 80 mm

CABIN

- ▶ „cant-off“-system made of galvanized steel, adjustable guide shoes on both sides
- ▶ compensation device on suspension ropes
- ▶ type tested safety gear
- ▶ bumper rails

HINGED DOORS

- ▶ manual operated double hinged doors, made of galvanized steel in accordance to DIN 18090, production controlled by TÜV-authorities
- ▶ side frames made of galvanized steel according to drawing
- ▶ door locks type-tested by TÜV-authorities

MAINTENANCE DOOR

- ▶ double hinged door with sash lock
- ▶ side frames made of galvanized steel according to drawing

DRIVE UNIT

- ▶ drive unit with factory oil filling, standard motor IP54, disc brake and hand wheel, 3 x 400 V / 50 Hz.
- ▶ 2 chain wheels for chains 5/8" x 3/8" suspension 2:1

CONTROLLER

- ▶ call and send control with 24 V, safety circuit 48 V
- ▶ pre-wired with plugs
- ▶ adjustable and time-limited despatch delay device (1-5 s)
- ▶ acoustic arrival signal
- ▶ electronic overload contact
- ▶ position indicator on each entrance
- ▶ thermic motor protection as main switch pre-wired on control panel
- ▶ machine room light with socket
- ▶ return control in headroom

SKG

**GOODS LIFT
WITH 1 TRAINED PERSON ▶▶**

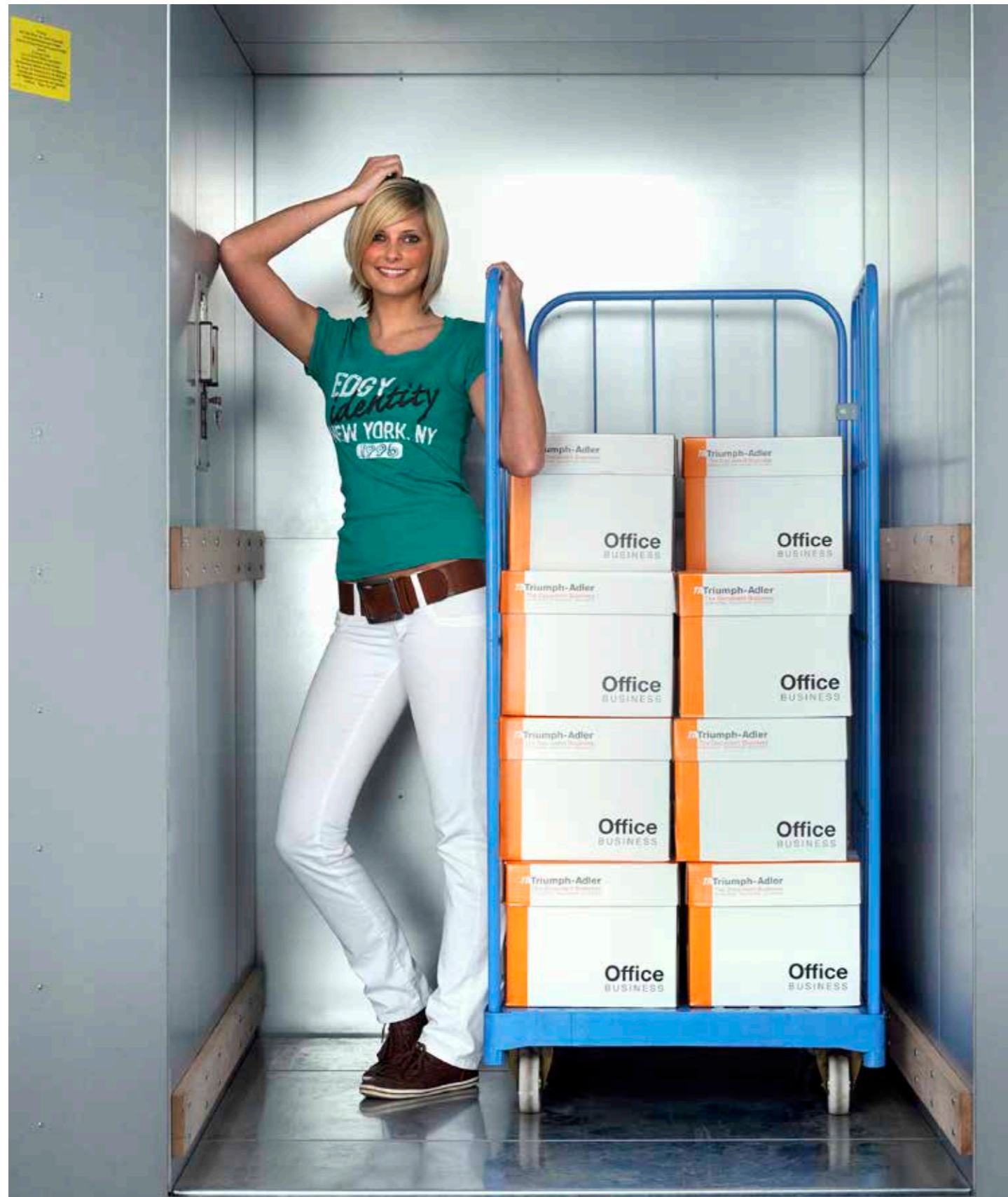

ISO-PE EASY

LOADING FRONT AND REAR, MACHINE ABOVE, WITH SAFETY GEAR

Shaft and pit dimensions are min. plumbed dimensions. The cabin width and depth available in increments of 25 mm. The cabin height is available in increments of 100 mm. **ATTENTION:** Cabin protection reduces clear entrance openings resp. shaft sizes (please refer to the SKG-OPTIONS)!

The shaft bottom must be carried out according to the construction drawing!

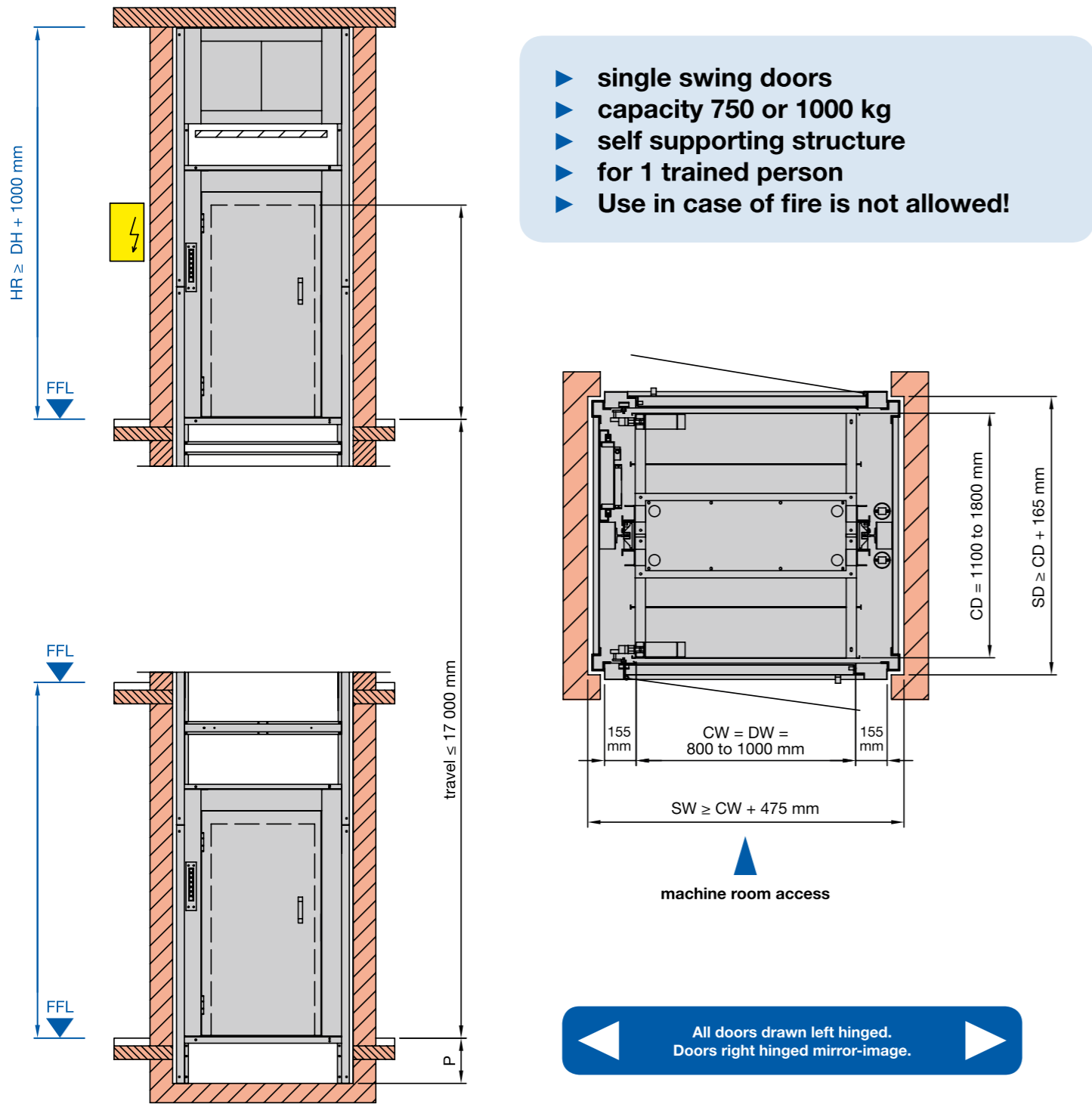

CW	=	cabin width		min. 800 to max. 1000 mm
CD	=	cabin depth		min. 1100 to max. 1800 mm
CH	=	cabin height		min. 2000 to max. 2200 mm
DW	=	door width	=	cabin width
DH	=	door height	=	cabin height
P	=	pit	=	min. 200 mm
SW	=	shaft width	=	plumbed min. dimensions
SD	=	shaft depth	=	plumbed min. dimensions
HR	=	headroom	=	clear height of top floor FFL-underside ceiling
FFL	=	finished floor level		

LOADING FRONT AND REAR, MACHINE ABOVE, WITH SAFETY GEAR

capacity	cabin floor area	speed	cabin height	2 stops 2 landings	3 stops 3 landings	4 stops 4 landings	5 stops 5 landings
750 kg	up to 1,8 m ²	0,1 m/s	2 to 2,2 m	31.183,- € PE.02.750.20.02	32.663,- € PE.02.750.20.03	34.175,- € PE.02.750.20.04	35.855,- € PE.02.750.20.05
1000 kg	up to 1,8 m ²	0,1 m/s	2 to 2,2 m	31.983,- € PE.02.1000.20.02	33.463,- € PE.02.1000.20.03	34.975,- € PE.02.1000.20.04	36.655,- € PE.02.1000.20.05

- ▶ complies to machine directive 2006/42/EC
- ▶ 3 meters of travel included for each stop

MAXIMAL 1 PERSON ACCOMPANYING THE GOODS !!!

STANDARD EQUIPMENT AT NO EXTRA-CHARGE

STRUCTURE

- ▶ self-supporting steel structure made of cold rolled profiles in galvanized finish
- ▶ pre-installed with T-guide rails T 70 x 65 x 9 mm
- ▶ compensation device on suspension elements
- ▶ baffle plates

CABIN

- ▶ „cant-off“-system made of galvanized steel
- ▶ adjustable guide shoes on both sides
- ▶ emergency light
- ▶ recessed cabin light
- ▶ cabin push button station with pre-adjusted emergency call, emergency light and emergency distance call
- ▶ type tested safety gear
- ▶ push button station with key switch (Hold-to-run)
- ▶ bumper rails

HINGED DOORS

- ▶ manual operated hinged doors made of galvanized steel in accordance to DIN 18090
- ▶ production controlled by TÜV-authorities
- ▶ side frames made of galvanized steel
- ▶ type-tested door locks

MAINTENANCE ROOM DOOR

- ▶ double hinged swing door with sash lock
- ▶ side frames made of galvanized steel according to drawing
- ▶ contact

DRIVE UNIT

- ▶ drive unit with standard motor IP 54 and oil filling by factory
- ▶ redundant brake system
- ▶ disc brake and hand wheel
- ▶ rotary current 400 V % 50 HZ along IEC
- ▶ 2 chain wheels for 2 chains 5/8" x 3/8"

CONTROLLER

- ▶ call and send control
- ▶ robust controller in controller cabinet
- ▶ return control in headroom
- ▶ "hold-to-run"-control (push button station inside the cabin is activated by key switch)
- ▶ electrical overload device

LOADING FRONT AND REAR, MACHINE ABOVE, **WITH SAFETY GEAR**

Shaft and pit dimensions are min. plumbed dimensions. The cabin width and depth available in increments of 25 mm. The cabin height is available in increments of 100 mm. **ATTENTION:** Cabin protection reduces clear entrance openings resp. shaft sizes (please refer to the SKG-OPTIONS)!

The shaft bottom must be carried out according to the construction drawing!

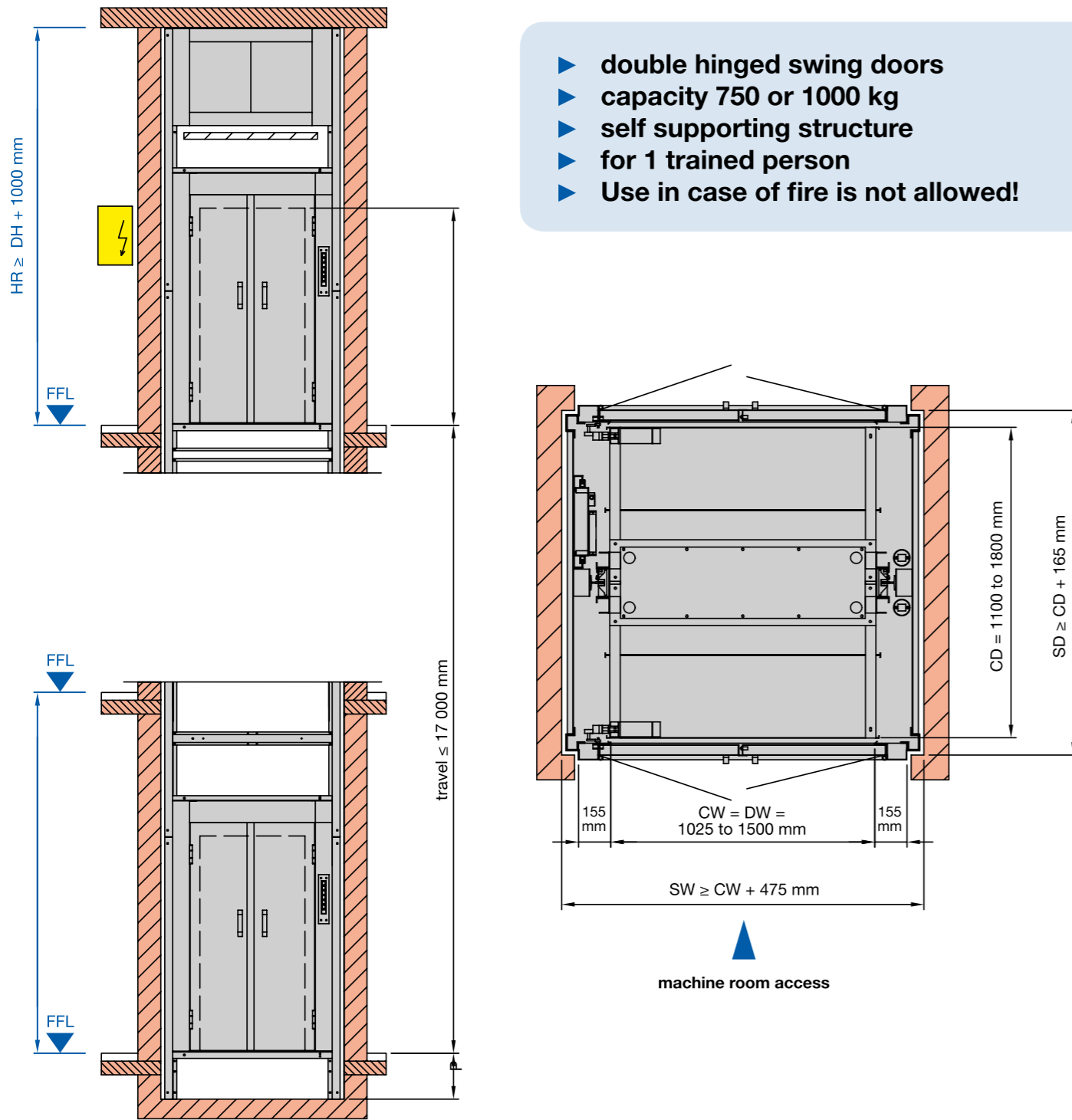

- ▶ double hinged swing doors
- ▶ capacity 750 or 1000 kg
- ▶ self supporting structure
- ▶ for 1 trained person
- ▶ Use in case of fire is not allowed!

CW	=	cabin width	=	min. 1025 to max. 1500 mm
CD	=	cabin depth	=	min. 1100 to max. 1800 mm
CH	=	cabin height	=	min. 2000 to max. 2200 mm
DW	=	door width	=	cabin width
DH	=	door height	=	cabin height
P	=	pit	=	min. 200 mm
SW	=	shaft width	=	plumbed min. dimensions
SD	=	shaft depth	=	plumbed min. dimensions
HR	=	headroom	=	clear height of top floor FFL-underside ceiling
FFL	=	finished floor level	=	

LOADING FRONT AND REAR, MACHINE ABOVE, **WITH SAFETY GEAR**

capacity	cabin floor area	speed	cabin height	2 stops 2 landings	3 stops 3 landings	4 stops 4 landings	5 stops 5 landings
750 kg	up to 2,7 m ²	0,1 m/s	2 to 2,2 m	33.335,- € PE.02.750.30.02	34.805,- € PE.02.750.30.03	36.328,- € PE.02.750.30.04	38.008,- € PE.02.750.30.05
1000 kg	up to 2,7 m ²	0,1 m/s	2 to 2,2 m	34.805,- € PE.02.1000.30.02	36.275,- € PE.02.1000.30.03	37.903,- € PE.02.1000.30.04	39.478,- € PE.02.1000.30.05

- ▶ complies to machine directive 2006/42/EC
- ▶ 3 meters of travel included for each stop



MAXIMAL 1 PERSON ACCOMPANYING THE GOODS !!!

STANDARD EQUIPMENT AT NO EXTRA-CHARGE

STRUCTURE

- ▶ self-supporting steel structure made of cold rolled profiles in galvanized finish
- ▶ pre-installed with T-guide rails T 70 x 65 x 9 mm
- ▶ compensation device on suspension elements
- ▶ baffle plates

CABIN

- ▶ „cant-off“-system made of galvanized steel
- ▶ adjustable guide shoes on both sides
- ▶ emergency light
- ▶ recessed cabin light
- ▶ cabin push button station with pre-adjusted emergency call, emergency light and emergency distance call
- ▶ type tested safety gear
- ▶ push button station with key switch (Hold-to-run)
- ▶ bumper rails

HINGED DOORS

- ▶ manual operated hinged doors made of galvanized steel in accordance to DIN 18090
- ▶ production controlled by TÜV-authorities
- ▶ side frames made of galvanized steel
- ▶ type-tested door locks

MAINTENANCE ROOM DOOR

- ▶ double hinged swing door with sash lock
- ▶ side frames made of galvanized steel according to drawing
- ▶ contact

DRIVE UNIT

- ▶ drive unit with standard motor IP 54 and oil filling by factory
- ▶ redundant brake system
- ▶ disc brake and hand wheel
- ▶ rotary current 400 V % 50 HZ along IEC
- ▶ 2 chain wheels for 2 chains 5/8" x 3/8"

CONTROLLER

- ▶ call and send control
- ▶ robust controller in controller cabinet
- ▶ return control in headroom
- ▶ "hold-to-run"-control (push button station inside the cabin is activated by key switch)
- ▶ electrical overload device

SKG

Metallschneider GmbH
Mühlenfeld 22
33154 Salzkotten-Verlar
GERMANY

phone +49 (0) 2948 9480-0
fax +49 (0) 2948 9480-24

info@metallschneider.de
www.metallschneider.de

